



A TEREX BRAND

Service Manual

Serial Number Range

GR™-12

from GR05-5001

GR™-15

from GR05-5001

GR™-20

from GR05-5001

QS-12R

from QS09-101

QS-15R

from QS09-101

QS-20R

from QS09-101

QS-12W

from QS09-101

QS-15W

from QS09-101

QS-20W

from QS09-101

Part No. 84700

Rev C1

January 2011

Introduction

Important

Read, understand and obey the safety rules and operating instructions in the appropriate Operator's Manual on your machine before attempting any maintenance procedure.

Basic mechanical, hydraulic and electrical skills are required to perform most procedures. However, several procedures require specialized skills, tools, lifting equipment and a suitable workshop. In these instances, we strongly recommend that maintenance and repair be performed at an authorized Genie dealer service center.

Compliance

Machine Classification

Group A/Type 2,3 as defined by ISO 16368

Machine Design Life

Unrestricted with proper operation, inspection and scheduled maintenance.

Technical Publications

Genie Industries has endeavored to deliver the highest degree of accuracy possible. However, continuous improvement of our products is a Genie policy. Therefore, product specifications are subject to change without notice.

Readers are encouraged to notify Genie of errors and send in suggestions for improvement. All communications will be carefully considered for future printings of this and all other manuals.

Contact Us:

www.genieindustries.com
e-mail: techpub@terex.com

Serial Number Information

Genie Industries offers the following Service Manuals for these models:

Title	Part No.
Genie Runabout Service Manual, First Edition (before serial number GR05-5001)	72965

Copyright © 2001 by Genie Industries

84700 Rev C September 2009
Second Edition, Third Printing

"Genie" is a registered trademark of Genie Industries in the USA and many other countries. "GR" is a trademark of Genie Industries.

 Printed on recycled paper

Printed in U.S.A.

Serial Number Legend

MANUFACTURED BY/FABRIQUE PAR:
 Genie Industries
 18340 NE 76th Street
 Redmond, WA 98052 USA



Model: GR-15
Serial number: GR05-1234
Model year: 2008 **Manufacture date:** 4/14/08
Elec/Hydr Schematic: ES0126/HS0039
Power supply voltage/Pneumatic Pressure:
 85-264 VAC, 60/50 Hz, 900 W
Nominal Power: 8.3 Hp / 6.2 kW
Machine unladen weight: 2,250 lbs / 1,021 kg
Max Load: 500 lbs / 227 kg
Occupants and Equipment must not exceed:
 500 lbs / 227 kg
Maximum allowable inclination of the chassis:
 1.5°(Side) 3°(Front) 3°(Rear)
Maximum Wind Speed:
Indoor: 28 mph / 12.5 m/s
Outdoor: 28 mph / 12.5 m/s
Gradeability: 30%
Maximum allowable side force: 100 lbs / 445 N
Maximum platform height: 14 ft 8 in / 4.47 m
Maximum Travel Height: Full ht
Maximum number of platform occupants: 1
Country of manufacture: USA
This machine complies with:
 EN 280
 98/37/EC



PN- 77172

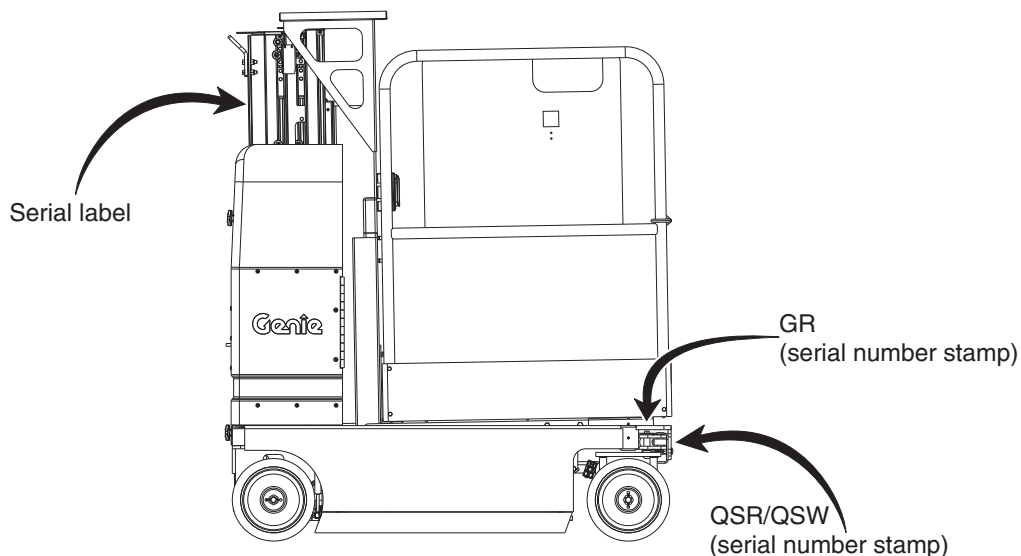
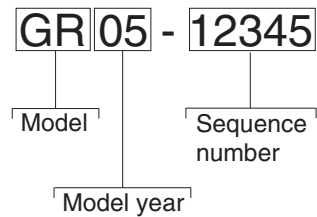

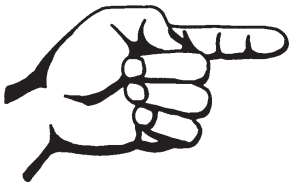
This page intentionally left blank.

Safety Rules



Danger

Failure to obey the instructions and safety rules in this manual and the appropriate Operator's Manual on your machine will result in death or serious injury.

Many of the hazards identified in the operator's manual are also safety hazards when maintenance and repair procedures are performed.

Do Not Perform Maintenance Unless:

- You are trained and qualified to perform maintenance on this machine.
- You read, understand and obey:
 - manufacturer's instructions and safety rules
 - employer's safety rules and worksite regulations
 - applicable governmental regulations
- You have the appropriate tools, lifting equipment and a suitable workshop.

SAFETY RULES

Personal Safety

Any person working on or around a machine must be aware of all known safety hazards. Personal safety and the continued safe operation of the machine should be your top priority.



Read each procedure thoroughly. This manual and the decals on the machine, use signal words to identify the following:



Safety alert symbol—used to alert personnel to potential personal injury hazards. Obey all safety messages that follow this symbol to avoid possible injury or death.



Indicates an imminently hazardous situation which, if not avoided, will result in death or serious injury.



Indicates a potentially hazardous situation which, if not avoided, could result in death or serious injury.



Indicates a potentially hazardous situation which, if not avoided, may cause minor or moderate injury.



Indicates a potentially hazardous situation which, if not avoided, may result in property damage.



Be sure to wear protective eye wear and other protective clothing if the situation warrants it.



Be aware of potential crushing hazards such as moving parts, free swinging or unsecured components when lifting or placing loads. Always wear approved steel-toed shoes.

Workplace Safety



Be sure to keep sparks, flames and lighted tobacco away from flammable and combustible materials like battery gases and engine fuels. Always have an approved fire extinguisher within easy reach.



Be sure that all tools and working areas are properly maintained and ready for use. Keep work surfaces clean and free of debris that could get into machine components and cause damage.



Be sure any forklift, overhead crane or other lifting or supporting device is fully capable of supporting and stabilizing the weight to be lifted. Use only chains or straps that are in good condition and of ample capacity.



Be sure that fasteners intended for one time use (i.e., cotter pins and self-locking nuts) are not reused. These components may fail if they are used a second time.



Be sure to properly dispose of old oil or other fluids. Use an approved container. Please be environmentally safe.



Be sure that your workshop or work area is properly ventilated and well lit.

Table of Contents

Introduction

Important Information	<i>ii</i>
Serial Number Information	<i>ii</i>
Serial Number Legend	<i>iii</i>

Section 1

Safety Rules

General Safety Rules	<i>v</i>
----------------------------	----------

Section 2

Rev

Specifications

D	Machine Specifications	2 - 1
	Performance Specifications	2 - 2
	Hydraulic Specifications	2 - 3
	Manifold Component Specifications	2 - 4
	Hydraulic Hose and Fitting Torque Specifications	2 - 5
	SAE and Metric Fasteners Torque Charts	2 - 7

Section 3

Rev

Scheduled Maintenance Procedures

	Introduction	3 - 1
	Pre-delivery Preparation Report	3 - 3
	Maintenance Inspection Report	3 - 5
D	Checklist A Procedures	
	A-1 Inspect the Manuals and Decals	3 - 6
	A-2 Perform Pre-operation Inspection	3 - 7
	A-3 Perform Function Tests	3 - 7
	A-4 Test the Obstruction Sensing System (QSR models only)	3 - 8
	A-5 Perform 30 Day Service	3 - 9
	A-6 Grease the Steer Yokes	3 - 9

TABLE OF CONTENTS

Section 3	Rev	Scheduled Maintenance Procedures, continued	
	D	Checklist B Procedures	
		B-1 Inspect the Batteries	3 - 10
		B-2 Inspect the Electrical Wiring	3 - 12
		B-3 Inspect the Tires and Wheels (including castle nut torque)	3 - 13
		B-4 Check the Lifting Chain Adjustments	3 - 13
		B-5 Clean and Lubricate the Columns	3 - 14
		B-6 Adjust the Sequencing Cables	3 - 14
		B-7 Test the Emergency Stop	3 - 15
		B-8 Test the Key Switch	3 - 16
		B-9 Test the Automotive-style Horn (if equipped)	3 - 16
		B-10 Inspect the Voltage Inverter (if equipped)	3 - 17
		B-11 Test the Drive Brakes	3 - 18
		B-12 Test the Drive Speed - Stowed Position	3 - 19
		B-13 Test the Drive Speed - Raised Position	3 - 20
		B-14 Test the Slow Drive Speed	3 - 21
		B-15 Test the Motion Alarm (if equipped)	3 - 22
		B-16 Test the Flashing Beacons (if equipped)	3 - 23
		B-17 Perform Hydraulic Oil Analysis	3 - 23
		B-18 Inspect the Breather Cap	3 - 24
	D	Checklist C Procedures	
		C-1 Grease the Platform Overload Mechanism (if equipped)	3 - 25
		C-2 Replace the Hydraulic Tank Breather Cap - Models with Optional Hydraulic Oil	3 - 25
		C-3 Test the Platform Overload System (if equipped)	3 - 26
	D	Checklist D Procedures	
		D-1 Inspect the Mast Assembly for Wear	3 - 28
		D-2 Inspect and Lubricate the Lifting Chains	3 - 29
		D-3 Replace the Hydraulic Tank Return Filter	3 - 30
	B	Checklist E Procedure	
		E-1 Test or Replace the Hydraulic Oil	3 - 31

TABLE OF CONTENTS

Section 4	Rev	Repair Procedures	
		Introduction	4 - 1
	E	Platform Controls	
		1-1 Circuit Boards	4 - 2
		1-2 Controller Adjustments	4 - 3
		1-3 Software Configuration	4 - 8
	C	Platform Components	
		2-1 Platform	4 - 12
		2-2 Platform Extension	4 - 12
		2-3 Work Tray	4 - 13
	B	Mast Components	
		3-1 Mast	4 - 14
		3-2 Glide Pads	4 - 18
		3-3 Lifting Chains	4 - 18
		3-4 Lift Cylinder	4 - 21
	B	Ground Controls	
		4-1 Level Sensor	4 - 22
	A	Hydraulic Pump	
		5-1 Function Pump	4 - 25
	B	Function Manifold	
		6-1 Function Manifold Components	4 - 28
		6-2 Valve Adjustments - Function Manifold	4 - 30
		6-3 Valve Coils	4 - 34
	A	Hydraulic Tank	
		7-1 Hydraulic Tank	4 - 36
	A	Steer Axle Components	
		8-1 Yoke and Drive Motor	4 - 37
		8-2 Steer Cylinder	4 - 39
		8-3 Steer Bellcrank	4 - 39

TABLE OF CONTENTS

Section 4	Rev	Repair Procedures, continued	
	A	Non-steer Axle Components	
		9-1 Drive Brake	4 - 40
	A	Brake Release Hand Pump Components	
		10-1 Brake Release Hand Pump Components	4 - 41
	B	Platform Overload Components	
		11-1 Platform Overload System	4 - 42
	A	Obstruction Sensing System	
		11-1 Obstruction Sensing Pads (QSR models only)	4 - 44
<hr/>			
Section 5	Rev	Fault Codes	
		Introduction	5 - 1
	C	Fault Code Chart	5 - 3
<hr/>			
Section 6	Rev	Schematics	
		Introduction	6 - 1
	C	Electrical Component and Wire Color Legends	6 - 2
	B	ECM Pin-out Legend	6 - 3
	C	Relay Layout	6 - 4
	B	Wiring Diagram - Ground and Platform Controls	6 - 5
	B	Electrical Symbols Legend	6 - 6
	C	Electrical Schematic - GR and QSW - ANSI and CSA Models (all models without platform overload protection)	6 - 8
	D	Electrical Schematic - GR and QSW - CE models (all models with platform overload protection)	6 - 10
	A	Electrical Schematic - QSR - ANSI and CSA Models (all models without platform overload protection)	6 - 14
	A	Electrical Schematic - QSR - CE models (all models with platform overload protection)	6 - 18
	A	Hydraulic Component Reference and Symbols Legend	6 - 22
	A	Hydraulic Schematic	6 - 23

REV D

Specifications

Machine Specifications

Batteries, Standard

Voltage	6V DC
Group	GC2
Type	T-105
Quantity	4
Battery capacity, maximum	225AH
Reserve capacity @ 25A rate	447 minutes

Batteries, Maintenance-free (option)

Voltage	6V DC
Group	GC2
Type	6V-AGM
Quantity	4
Battery capacity, maximum	200AH
Reserve capacity @ 25A rate	380 minutes

Fluid capacities

Hydraulic tank	1.5 gallons 5.7 liters
Hydraulic system (including tank)	2.2 gallons 8.3 liters

Height, stowed maximum

GR-12, GR-15, QS-12R, QS-15R QS-12W and QS-15W (ANSI, CSA and Australia models)	62 in 1.57 m
GR-12 and GR-15 (CE models)	68.1 in 1.73 m
GR-20, QS-20R and QS-20W (all models)	78 in 1.98 m

Tires and wheels

Tire size (solid rubber)	10 x 3 in 25.4 x 2.5 cm
Tire contact area	6.5 sq in 41.9 cm ²
Castle nut torque, lubricated	150 ft-lbs 203 Nm

Continuous improvement of our products is a Genie policy. Product specifications are subject to change without notice.

For operational specifications, refer to the Operator's Manual.

SPECIFICATIONS

REV D

Performance Specifications

Drive speed, maximum

Platform stowed, fast	2.5 mph 40 ft / 10.9 sec 4 km/h 12.2 m / 10.9 sec
Platform stowed, slow	1.1 mph 40 ft / 24.8 sec 1.8 km/h 12.2 m / 24.8 sec
Platform raised	0.5 mph 40 ft / 55 sec 0.8 km/h 12.2 m / 55 sec

Braking distance, maximum

High range on paved surface	19 in ± 6 in 48 cm ± 15 cm
-----------------------------	-------------------------------

Gradeability 30%

Airborne noise emissions Maximum sound level at normal operation workstations (A-weighted)	70 dB
--	-------

Function speed, maximum from platform controls (with 1 person in platform)

GR-12, QS-12R and QS-12W

Platform up	19 to 21 seconds
Platform down	17 to 19 seconds

GR-15, QS-15R and QS-15W

Platform up	20 to 22 seconds
Platform down	18 to 20 seconds

GR-20, QS-20R and QS-20W

Platform up	23 to 25 seconds
Platform down	20 to 22 seconds

Rated work load at full height, maximum

GR-12 and GR-15

Standard Platform	500 lbs 227 kg
-------------------	-------------------

GR-20

Standard Platform	350 lbs 159 kg
-------------------	-------------------

GR-12, GR-15 and GR-20

AWP and Fiberglass Platform	350 lbs 159 kg
-----------------------------	-------------------

GR-12, GR-15, QS-12R, QS-15R, QS-12W and QS-15W

Stockpicker Platform	500 lbs 227 kg
----------------------	-------------------

GR-20, QS-20R and QS-20W

Stockpicker Platform	350 lbs 159 kg
----------------------	-------------------

Continuous improvement of our products is a Genie policy. Product specifications are subject to change without notice.

REV D

SPECIFICATIONS

Hydraulic Specifications

Hydraulic Oil Specifications

Hydraulic oil type	Chevron Rando HD equivalent
Viscosity grade	Multi-viscosity
Viscosity index	200
Cleanliness level, minimum	15/13
Water content, maximum	200 ppm

Chevron Rando HD oil is fully compatible and mixable with Shell Donax TG (Dexron III) oils.

Genie specifications require hydraulic oils which are designed to give maximum protection to hydraulic systems, have the ability to perform over a wide temperature range, and the viscosity index should exceed 140. They should provide excellent antiwear, oxidation, corrosion inhibition, seal conditioning, and foam and aeration suppression properties.

Optional fluids

Biodegradable	Petro Canada Environ MV 46 Statoil Hydra Way Bio SE 32 BP Biohyd SE-S
Fire resistant	UCON Hydrolube HP-5046 Quintolubric 822
Mineral based	Shell Tellus T32 Shell Tellus T46 Chevron Aviation A

NOTICE Continued use of Chevron Aviation A hydraulic fluid when ambient temperatures are consistently above 32°F / 0°C may result in component damage.

Note: Use Chevron Aviation A hydraulic fluid when ambient temperatures are consistently below 0°F / -17°C.

Note: Use Shell Tellus T46 hydraulic oil when oil temperatures consistently exceed 205°F / 96°C.

Note: Genie specifications require additional equipment and special installation instructions for the approved optional fluids. Consult the Genie Industries Service Department before use.

Function pump

Type	Gear
Displacement per revolution	0.244 cu in 4 cc
Flow rate @ 2500 psi / 172 bar	4 gpm 15 L/min
Hydraulic tank return filter	10 micron with 25 psi / 1.7 bar bypass

Function manifold

System relief valve pressure, maximum	3500 psi 241 bar
Lift relief valve pressure	1800 to 3500 psi 124 to 241 bar
Steer relief valve pressure	1500 psi 103 bar

Continuous improvement of our products is a Genie policy. Product specifications are subject to change without notice.

SPECIFICATIONS

REV D

Manifold Component Specifications

Plug torque

SAE No. 2	50 in-lbs / 6 Nm
SAE No. 4	13 ft-lbs / 18 Nm
SAE No. 6	18 ft-lbs / 24 Nm
SAE No. 8	50 ft-lbs / 68 Nm
SAE No. 10	55 ft-lbs / 75 Nm
SAE No. 12	75 ft-lbs / 102 Nm

Valve Coil Resistance

Note: The following coil resistance specifications are at an ambient temperature of 68°F / 20°C. As valve coil resistance is sensitive to changes in air temperature, the coil resistance will typically increase or decrease by 4% for each 18°F / -7.7°C that your air temperature increases or decreases from 68°F / 20°C.

Description	Specification
Solenoid valve, 3 position 4 way 20V DC with diode (schematic item E)	27.2Ω
Solenoid valve, 3 position 4 way 20V DC with diode (schematic item F)	19Ω
Solenoid valve, 2 position 4 way 20V DC with diode (schematic item H)	25Ω
Solenoid valve, 2 position 2 way N.C. with manual override 12V DC with diode (schematic item N)	6.25Ω

Continuous improvement of our products is a Genie policy. Product specifications are subject to change without notice.

REV D

SPECIFICATIONS

Hydraulic Hose and Fitting Torque Specifications

Your machine is equipped with JIC 37° flared fittings and hose ends. Genie specifications require that fittings and hose ends be torqued to specification when they are removed and installed or when new hoses or fittings are installed.

SAE O-ring Boss Port

(tube fitting - installed into Aluminum)

SAE Dash size	Torque
-4	11 ft-lbs / 14.9 Nm
-6	23 ft-lbs / 31.2 Nm
-8	40 ft-lbs / 54.2 Nm
-10	69 ft-lbs / 93.6 Nm
-12	93 ft-lbs / 126.1 Nm
-16	139 ft-lbs / 188.5 Nm
-20	172 ft-lbs / 233.2 Nm
-24	208 ft-lbs / 282 Nm

SAE O-ring Boss Port

(tube fitting - installed into Steel)

SAE Dash size	Torque
-4	16 ft-lbs / 21.7 Nm
-6	35 ft-lbs / 47.5 Nm
-8	60 ft-lbs / 81.3 Nm
-10	105 ft-lbs / 142.4 Nm
-12	140 ft-lbs / 190 Nm
-16	210 ft-lbs / 284.7 Nm
-20	260 ft-lbs / 352.5 Nm
-24	315 ft-lbs / 427.1 Nm

JIC 37° Fittings

(swivel nut or hose connection)

SAE Dash size	Thread Size	Flats
-4	7/16-20	2
-6	9/16-18	1 1/4
-8	3/4-16	1
-10	7/8-14	1
-12	1 1/16-12	1
-16	1 5/16-12	1
-20	1 5/8-12	1
-24	1 7/8-12	1

SPECIFICATIONS

REV D

Torque Procedure

JIC 37° fittings

- 1 Align the tube flare (hex nut) against the nose of the fitting body (body hex fitting) and tighten the hex nut to the body hex fitting to hand-tight, approximately 30 in-lbs / 3.4 Nm.
- 2 Make a reference mark on one of the flats of the hex nut, and continue it on to the body hex fitting with a permanent ink marker. Refer to Figure 1.

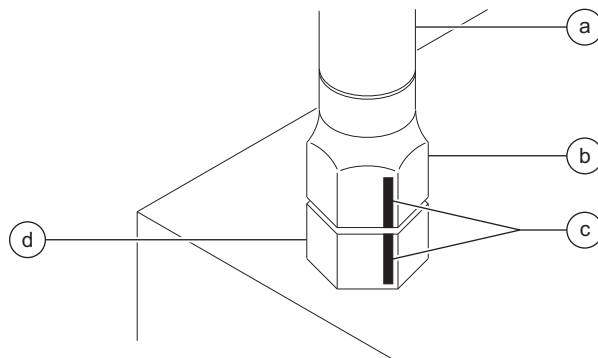

Figure 1

- a hydraulic hose
- b hex nut
- c reference mark
- d body hex fitting

- 3 Working clockwise on the body hex fitting, make a second mark with a permanent ink marker to indicate the proper tightening position. Refer to Figure 2.

NOTICE Use the *JIC 37° Fittings* table on the previous page to determine the correct number of flats for the proper tightening position.

NOTICE The marks indicate that the correct tightening positions have been determined. Use the second mark on the body hex fitting to properly tighten the joint after it has been loosened.

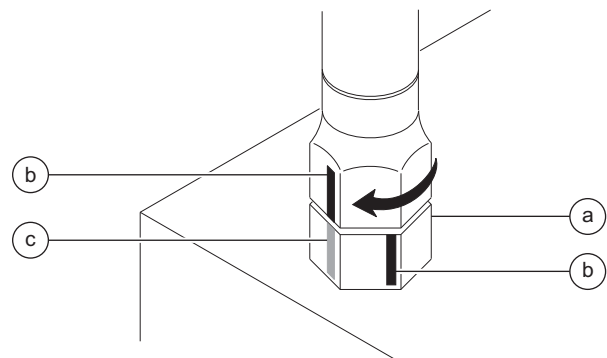



Figure 2





- a body hex fitting
- b reference mark
- c second mark

- 4 Tighten the hex nut until the mark on the hex nut is aligned with the second mark on the body hex fitting.
- 5 Operate all machine functions and inspect the hoses and fittings and related components to confirm that there are no leaks.

REV D

SPECIFICATIONS

SAE FASTENER TORQUE CHART											
• This chart is to be used as a guide only unless noted elsewhere in this manual •											
SIZE	THREAD	Grade 5 				Grade 8 				A574 High Strength Black Oxide Bolts	
		LUBED		DRY		LUBED		DRY		LUBED	
		in-lbs	Nm	in-lbs	Nm	in-lbs	Nm	in-lbs	Nm	in-lbs	Nm
1/4	20	80	9	100	11.3	110	12.4	140	15.8	130	14.7
	28	90	10.1	120	13.5	120	13.5	160	18	140	15.8
		LUBED		DRY		LUBED		DRY		LUBED	
		ft-lbs	Nm	ft-lbs	Nm	ft-lbs	Nm	ft-lbs	Nm	ft-lbs	Nm
5/16	18	13	17.6	17	23	18	24	25	33.9	21	28.4
	24	14	19	19	25.7	20	27.1	27	36.6	24	32.5
3/8	16	23	31.2	31	42	33	44.7	44	59.6	38	51.5
	24	26	35.2	35	47.4	37	50.1	49	66.4	43	58.3
7/16	14	37	50.1	49	66.4	50	67.8	70	94.7	61	82.7
	20	41	55.5	55	74.5	60	81.3	80	108.4	68	92.1
1/2	13	57	77.3	75	101.6	80	108.4	110	149	93	126
	20	64	86.7	85	115	90	122	120	162	105	142
9/16	12	80	108.4	110	149	120	162	150	203	130	176
	18	90	122	120	162	130	176	170	230	140	189
5/8	11	110	149	150	203	160	217	210	284	180	244
	18	130	176	170	230	180	244	240	325	200	271
3/4	10	200	271	270	366	280	379	380	515	320	433
	16	220	298	300	406	310	420	420	569	350	474
7/8	9	320	433	430	583	450	610	610	827	510	691
	14	350	474	470	637	500	678	670	908	560	759
1	8	480	650	640	867	680	922	910	1233	770	1044
	12	530	718	710	962	750	1016	990	1342	840	1139
1 1/8	7	590	800	790	1071	970	1315	1290	1749	1090	1477
	12	670	908	890	1206	1080	1464	1440	1952	1220	1654
1 1/4	7	840	1138	1120	1518	1360	1844	1820	2467	1530	2074
	12	930	1260	1240	1681	1510	2047	2010	2725	1700	2304
1 1/2	6	1460	1979	1950	2643	2370	3213	3160	4284	2670	3620
	12	1640	2223	2190	2969	2670	3620	3560	4826	3000	4067

METRIC FASTENER TORQUE CHART																
• This chart is to be used as a guide only unless noted elsewhere in this manual •																
Size (mm)	Class 4.6 				Class 8.8 				Class 10.9 				Class 12.9 			
	LUBED		DRY		LUBED		DRY		LUBED		DRY		LUBED		DRY	
	in-lbs	Nm	in-lbs	Nm	in-lbs	Nm	in-lbs	Nm	in-lbs	Nm	in-lbs	Nm	in-lbs	Nm	in-lbs	Nm
5	16	1.8	21	2.4	41	4.63	54	6.18	58	6.63	78	8.84	68	7.75	91	10.3
6	19	3.05	36	4.07	69	7.87	93	10.5	100	11.3	132	15	116	13.2	155	17.6
7	45	5.12	60	6.83	116	13.2	155	17.6	167	18.9	223	25.2	1.95	22.1	260	29.4
	LUBED		DRY		LUBED		DRY		LUBED		DRY		LUBED		DRY	
	ft-lbs	Nm	ft-lbs	Nm	ft-lbs	Nm	ft-lbs	Nm	ft-lbs	Nm	ft-lbs	Nm	ft-lbs	Nm	ft-lbs	Nm
8	5.4	7.41	7.2	9.88	14	19.1	18.8	25.5	20.1	27.3	26.9	36.5	23.6	32	31.4	42.6
10	10.8	14.7	14.4	19.6	27.9	37.8	37.2	50.5	39.9	54.1	53.2	72.2	46.7	63.3	62.3	84.4
12	18.9	25.6	25.1	34.1	48.6	66	64.9	88	69.7	94.5	92.2	125	81	110	108	147
14	30.1	40.8	40	54.3	77.4	105	103	140	110	150	147	200	129	175	172	234
16	46.9	63.6	62.5	84.8	125	170	166	226	173	235	230	313	202	274	269	365
18	64.5	87.5	86.2	117	171	233	229	311	238	323	317	430	278	377	371	503
20	91	124	121	165	243	330	325	441	337	458	450	610	394	535	525	713
22	124	169	166	225	331	450	442	600	458	622	612	830	536	727	715	970
24	157	214	210	285	420	570	562	762	583	791	778	1055	682	925	909	1233



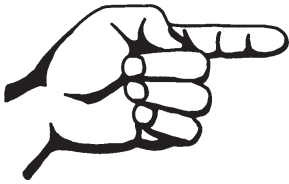

This page intentionally left blank.

Scheduled Maintenance Procedures



Observe and Obey:

- ☑ Maintenance inspections shall be completed by a person trained and qualified on the maintenance of this machine.
- ☑ Scheduled maintenance inspections shall be completed daily, quarterly, semi-annually, annually and every 2 years as specified on the *Maintenance Inspection Report*.

⚠ WARNING Failure to properly complete each inspection when required may cause death, serious injury or substantial machine damage.

- ☑ Immediately tag and remove from service a damaged or malfunctioning machine.
- ☑ Repair any machine damage or malfunction before operating the machine.
- ☑ Use only Genie approved replacement parts.
- ☑ Machines that have been out of service for a period longer than 3 months must complete the quarterly inspection.
- ☑ Unless otherwise specified, perform each procedure with the machine in the following configuration:
 - Machine parked on a firm, level surface
 - Platform in the stowed position
 - Key switch in the off position with the key removed
 - The red Emergency Stop button in the off position at both ground and platform controls
 - Wheels chocked
 - All external AC power supply disconnected from the machine

About This Section

This section contains detailed procedures for each scheduled maintenance inspection.

Each procedure includes a description, safety warnings and step-by-step instructions.

Symbols Legend



Safety alert symbol—used to alert personnel to potential personal injury hazards. Obey all safety messages that follow this symbol to avoid possible injury or death.

⚠ DANGER

Indicates an imminently hazardous situation which, if not avoided, will result in death or serious injury.

⚠ WARNING

Indicates a potentially hazardous situation which, if not avoided, could result in death or serious injury.

⚠ CAUTION

Indicates a potentially hazardous situation which, if not avoided, may cause minor or moderate injury.

NOTICE

Indicates a potentially hazardous situation which, if not avoided, may result in property damage.

- ⦿ Indicates that a specific result is expected after performing a series of steps.
- ⊗ Indicates that an incorrect result has occurred after performing a series of steps.

SCHEDULED MAINTENANCE PROCEDURES

Maintenance Symbols Legend

Note: The following symbols have been used in this manual to help communicate the intent of the instructions. When one or more of the symbols appears at the beginning of a maintenance procedure, it conveys the meaning below.



Indicates that tools will be required to perform this procedure.



Indicates that new parts will be required to perform this procedure.



Indicates that a cold motor or pump will be required to perform this procedure.



Indicates that dealer service will be required to perform this procedure.

Pre-delivery Preparation Report

The pre-delivery preparation report contains checklists for each type of scheduled inspection.

Make copies of the *Pre-delivery Preparation* report to use for each inspection. Store completed forms as required.

Maintenance Schedule

There are five types of maintenance inspections that must be performed according to a schedule—daily, quarterly, semi-annually, annually, and two year. The *Scheduled Maintenance Procedures Section and the Maintenance Inspection Report* have been divided into five subsections—A, B, C, D, and E. Use the following chart to determine which group(s) of procedures are required to perform a scheduled inspection.

Inspection	Checklist
Daily or every 8 hours	A
Quarterly or every 250 hours	A + B
Semi-annually or every 500 hours	A + B + C
Annually or every 1000 hours	A + B + C + D
Two year or every 2000 hours	A + B + C + D + E

Maintenance Inspection Report

The maintenance inspection report contains checklists for each type of scheduled inspection.

Make copies of the *Maintenance Inspection Report* to use for each inspection. Maintain completed forms for a minimum of 4 years or in compliance with employer, jobsite and governmental regulations and requirements.

Pre-Delivery Preparation

Fundamentals

It is the responsibility of the dealer to perform the Pre-delivery Preparation.

The Pre-delivery Preparation is performed prior to each delivery. The inspection is designed to discover if anything is apparently wrong with a machine before it is put into service.

A damaged or modified machine must never be used. If damage or any variation from factory delivered condition is discovered, the machine must be tagged and removed from service.

Repairs to the machine may only be made by a qualified service technician, according to the manufacturer's specifications.

Scheduled maintenance inspections shall be performed by qualified service technicians, according to the manufacturer's specifications and the requirements listed in the responsibilities manual.

Instructions

Use the operator's manual on your machine.

The Pre-delivery Preparation consists of completing the Pre-operation Inspection, the Maintenance items and the Function Tests.

Use this form to record the results. Place a check in the appropriate box after each part is completed. Follow the instructions in the operator's manual.

If any inspection receives an N, remove the machine from service, repair and re-inspect it. After repair, place a check in the R box.

Legend

Y = yes, completed

N = no, unable to complete

R = repaired

Comments

Pre-Delivery Preparation	Y	N	R
Pre-operation inspection completed			
Maintenance items completed			
Function tests completed			

Model

Serial number

Date

Machine owner

Inspected by (print)

Inspector signature

Inspector title

Inspector company

Genie®

A TEREX BRAND

Genie Industries USA
18340 NE 76th Street
PO Box 97030
Redmond, WA 98073-9730
(425) 881-1800

Genie UK
The Maltings, Wharf Road
Grantham, Lincolnshire
NG31-6BH England
(44) 1476-584333

Copyright © 2002 by Genie Industries. Genie® is a registered trademark of Genie Industries. Rev A



This page intentionally left blank.

Maintenance Inspection Report

Model
Serial number
Date
Hour meter
Machine owner
Inspected by (print)
Inspector signature
Inspector title
Inspector company

Instructions

- Make copies of this report to use for each inspection.
- Select the appropriate checklist(s) for the type of inspection to be performed.

<input type="checkbox"/>	Daily or 8 hours Inspection:	A
<input type="checkbox"/>	Quarterly or 250 hours Inspection:	A+B
<input type="checkbox"/>	Semi-annually or 500 hours Inspection:	A+B+C
<input type="checkbox"/>	Annually or 1000 hours Inspection:	A+B+C+D
<input type="checkbox"/>	Two year or 2000 hours Inspection:	A+B+C+D+E

- Place a check in the appropriate box after each inspection procedure is completed.
- Use the step-by-step procedures in this section to learn how to perform these inspections.
- If any inspection receives an "N", tag and remove the machine from service, repair and re-inspect it. After repair, place a check in the "R" box.

Legend

- Y = yes, acceptable
- N = no, remove from service
- R = repaired

Checklist A - Rev D		Y	N	R
A-1	Inspect the manuals and decals			
A-2	Pre-operation inspection			
A-3	Function tests			
A-4	Obstruction sensing system (QSR models)			
Perform after 40 hours:				
A-5	30 day service			
Perform every 100 hours:				
A-6	Grease steer yokes			

Checklist B - Rev D		Y	N	R
B-1	Batteries			
B-2	Electrical wiring			
B-3	Tires and wheels			
B-4	Lifting chain			
B-5	Clean columns			
B-6	Sequencing cables			
B-7	Emergency stop			
B-8	Key switch			
B-9	Horn (if equipped)			
B-10	Inverter (if equipped)			
B-11	Drive brakes			
B-12	Drive speed - stowed			
B-13	Drive speed - raised			
B-14	Drive speed - slow			
B-15	Alarm (if equipped)			
B-16	Flashing beacons (if equipped)			
B-17	Hydraulic oil analysis			
B-18	Breather cap			

Checklist C - Rev D		Y	N	R
C-1	Grease platform overload (if equipped)			
C-2	Breather cap - models with optional oil			
C-3	Test platform overload (if equipped)			

Checklist D - Rev D		Y	N	R
D-1	Inspect Mast			
D-2	Inspect/lubricate chains			
D-3	Hydraulic filter			

Checklist E - Rev B		Y	N	R
E-1	Hydraulic oil			

Comments

Checklist A Procedures

REV D

A-1 Inspect the Manuals and Decals

Maintaining the operator's and safety manuals in good condition is essential to safe machine operation. Manuals are included with each machine and should be stored in the container provided in the platform. An illegible or missing manual will not provide safety and operational information necessary for a safe operating condition.

In addition, maintaining all of the safety and instructional decals in good condition is mandatory for safe machine operation. Decals alert operators and personnel to the many possible hazards associated with using this machine. They also provide users with operation and maintenance information. An illegible decal will fail to alert personnel of a procedure or hazard and could result in unsafe operating conditions.

- 1 Check to make sure that the operator's and safety manuals are present and complete in the storage container on the platform.
 - 2 Examine the pages of each manual to be sure that they are legible and in good condition.
- ⊙ Result: The operator's manual is appropriate for the machine and all manuals are legible and in good condition.
 - ⊗ Result: The operator's manual is not appropriate for the machine or all manuals are not in good condition or is illegible. Remove the machine from service until the manual is replaced.

- 3 Open the operator's manual to the decals inspection section. Carefully and thoroughly inspect all decals on the machine for legibility and damage.
- ⊙ Result: The machine is equipped with all required decals, and all decals are legible and in good condition.
 - ⊗ Result: The machine is not equipped with all required decals, or one or more decals are illegible or in poor condition. Remove the machine from service until the decals are replaced.
- 4 Always return the manuals to the storage container after use.

Note: Contact your authorized Genie distributor or Genie Industries if replacement manuals or decals are needed.

REV D

CHECKLIST A PROCEDURES

A-2 Perform Pre-operation Inspection

Completing a Pre-operation Inspection is essential to safe machine operation. The Pre-operation Inspection is a visual inspection performed by the operator prior to each work shift. The inspection is designed to discover if anything is apparently wrong with a machine before the operator performs the function tests. The Pre-operation Inspection also serves to determine if routine maintenance procedures are required.

Complete information to perform this procedure is available in the appropriate operator's manual. Refer to the Operator's Manual on your machine.

A-3 Perform Function Tests

Completing the function tests is essential to safe machine operation. Function tests are designed to discover any malfunctions before the machine is put into service. A malfunctioning machine must never be used. If malfunctions are discovered, the machine must be tagged and removed from service.

Complete information to perform this procedure is available in the appropriate operator's manual. Refer to the Operator's Manual on your machine.

REV D

A-4 Test the Obstruction Sensing System (QSR models only)



Genie specifications require that this procedure be performed every 8 hours or daily, whichever comes first.

- 1 Raise the platform approximately 4 feet / 1.2 m.
- 2 Place a 15 lb / 6.8 kg weight onto one of the obstruction sensing pads, of an area equal to 3 inches / 7.3 cm in diameter.

Note: The weight must be placed approximately 2 inches / 5.08 cm from the edge of the obstruction sensing pad.

- 3 At the ground controls, attempt to lower the platform.
 - ⊙ Result: The obstruction sensing alarm sounds and the platform will not lower. The system is working properly.
 - ⊗ Result: The obstruction sensing alarm does not sound and the platform will lower. The system is not functioning correctly. Replace the pad. Refer to Repair procedure 12-1, *How to Replace an Obstruction Sensing Pad*.
- 4 Remove the the weight from the pad. Push in the red Emergency Stop button to the off position at the ground controls, then pull out the red Emergency Stop button to the on position at the ground controls.
- 5 Repeat the procedure, beginning with step 2, for each of the remaining obstruction sensing pads.

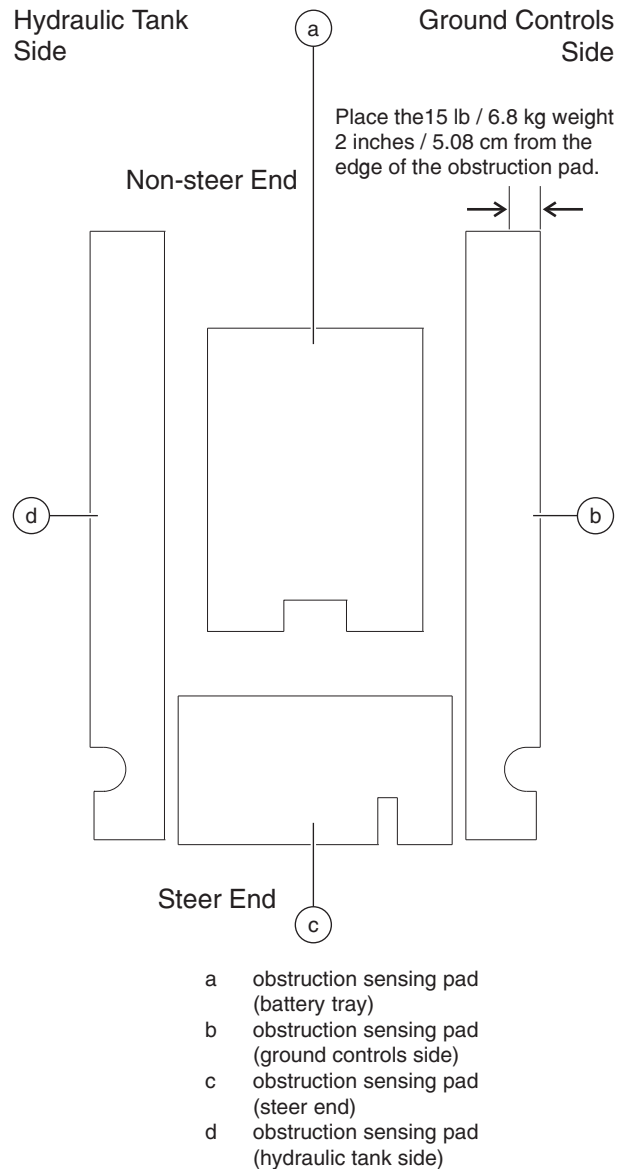

REV D

A-5 Perform 30 Day Service



The 30 day maintenance procedure is a one time procedure to be performed after the first 30 days or 40 hours of usage. After this interval, refer to the maintenance tables for continued scheduled maintenance.

1 Perform the following maintenance procedures:

- B-3 Inspect the Tires and Wheels (including castle nut torque)
- D-4 Replace the Hydraulic Tank Return Filter

A-6 Grease the Steer Yokes



Genie specifications require that this procedure be performed every 100 hours of operation.

Regular application of lubrication to the steer yokes is essential to good machine performance and service life. Continued use of an insufficiently greased steer yoke will result in component damage.

- 1 Locate the grease fitting on the top of the steer yoke.
- 2 Pump multipurpose grease into the steer yoke until the steer yoke is full and grease is being forced past the bearings. Repeat this step for the other steer yoke.

Grease Specification

Chevron Ultra-duty grease, EP NLGI 1 (lithium based) or equivalent

Checklist B Procedures

REV D

B-1 Inspect the Batteries



Genie specifications require that this procedure be performed every 250 hours or quarterly, whichever comes first.

Proper battery condition is essential to good machine performance and operational safety. Improper fluid levels or damaged cables and connections can result in component damage and hazardous conditions.

⚠ WARNING Electrocutation/burn hazard. Contact with hot or live circuits could result in death or serious injury. Remove all rings, watches and other jewelry.

⚠ WARNING Bodily injury hazard. Batteries contain acid. Avoid spilling or contacting battery acid. Neutralize battery acid spills with baking soda and water.

- 1 Put on protective clothing and eye wear.
- 2 **GR-12:** Raise the platform approximately 3 feet / 1 m.
GR-15 and GR-20: Raise the platform approximately 5 feet / 1.5 m.
- 3 Open the battery cover. Rest the cover against the chassis.
- 4 Lower the platform until the mast just contacts the battery cover.

⚠ WARNING Crushing hazard. Keep hands clear of the battery cover when lowering the platform.

- 5 Be sure that the battery cable connections are free of corrosion.

Note: Adding terminal protectors and a corrosion preventative sealant will help eliminate corrosion on the battery terminals and cables.

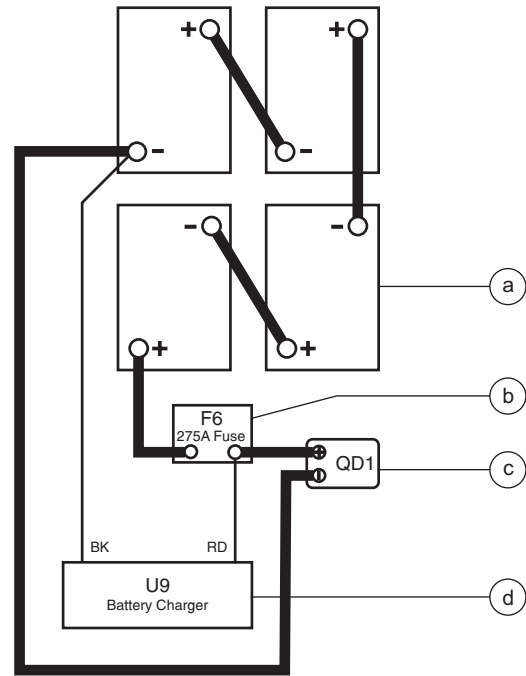

- a batteries B5
- b 275A fuse F6
- c quick disconnect QD1
- d battery charger U9

- 6 Be sure that the battery hold downs and cable connections are tight.
- 7 Be sure that the battery separator wire connections are tight (if equipped).
- 8 Fully charge the batteries. Allow the batteries to rest 24 hours before performing this procedure to allow the battery cells to equalize.
- 9 Put on protective clothing and eye wear.

Models without maintenance-free or sealed batteries:

- 10 Remove the battery vent caps and check the specific gravity of each battery cell with a hydrometer. Note the results.

REV D

CHECKLIST B PROCEDURES

11 Check the ambient air temperature and adjust the specific gravity reading for each cell as follows:

- Add 0.004 to the reading of each cell for every 10° / 5.5° C above 80° F / 26.7° C.
- Subtract 0.004 from the reading of each cell for every 10° / 5.5° C below 80° F / 26.7° C.
- ⊙ Result: All battery cells display an adjusted specific gravity of 1.277 or higher. The battery is fully charged. Proceed to step 15.

✗ Result: One or more battery cells display a specific gravity of 1.217 or below. Proceed to step 12.

12 Perform an equalizing charge OR fully charge the batteries and allow the batteries to rest at least 6 hours.

13 Remove the battery vent caps and check the specific gravity of each battery cell with a hydrometer. Note the results.

14 Check the ambient air temperature and adjust the specific gravity reading for each cell as follows:

- Add 0.004 to the reading of each cell for every 10° / 5.5° C above 80° F / 26.7° C.
- Subtract 0.004 from the reading of each cell for every 10° / 5.5° C below 80° F / 26.7° C.
- ⊙ Result: All battery cells display a specific gravity of 1.277 or greater. The battery is fully charged. Proceed to step 15.

✗ Result: The difference in specific gravity readings between cells is greater than 0.1 OR the specific gravity of one or more cells is less than 1.177. Replace the battery.

15 Check the battery acid level. If needed, replenish with distilled water to 1/8 inch / 3 mm below the bottom of the battery fill tube. Do not overfill.

16 Install the vent caps and neutralize any electrolyte that may have spilled.

All models:

17 Check each battery pack and verify that the batteries are wired correctly.

18 Inspect the battery charger plug and pigtail for damage or excessive insulation wear. Replace as required.

19 Connect the battery charger to a properly grounded 115V/60Hz or 230V/60Hz single phase AC power supply.

⊙ Result: The charger should operate and begin charging the batteries.

✗ If, simultaneously, the charger alarm sounds and the LEDs blink **one time**, correct the charger connections at the fuse and battery. The charger will then operate correctly and begin charging the batteries.

If, simultaneously, the charger alarm sounds and the LEDs blink **two times**, the input voltage is too low or too high. Correct the voltage issue. The charger will then operate correctly and begin charging the batteries.

If, simultaneously, the charger alarm sounds and the LEDs blink **three times**, the charger is overheated. Allow the charger to cool. The charger will then operate correctly and begin charging the batteries.

Note: For best results, use an extension of adequate size with a length no longer than 50 feet / 15 m.

Note: If you have any further questions regarding the battery charger operation, please contact the Genie Industries Scissor Service Department.

CHECKLIST B PROCEDURES

REV D

B-2 Inspect the Electrical Wiring



Genie specifications require that this procedure be performed every 250 hours or quarterly, whichever comes first.

Maintaining electrical wiring in good condition is essential to safe operation and good machine performance. Failure to find and replace burnt, chafed, corroded or pinched wires could result in unsafe operating conditions and may cause component damage.

⚠ WARNING Electrocutation/burn hazard. Contact with hot or live circuits could result in death or serious injury. Remove all rings, watches and other jewelry.

- 1 Inspect the underside of the chassis for damaged or missing ground straps.
- 2 Inspect the following areas for burnt, chafed, corroded and loose wires:
 - Mast cable
 - Platform controls
 - Power to platform wiring
- 3 Inspect the following areas for burnt, chafed, corroded and loose wires:
 - Ground control panel
 - Hydraulic power unit
- 4 Inspect for a liberal coating of dielectric grease in all wiring connections between the ECM and the platform controls, and level sensor wiring.
- 5 Turn the key switch to ground control and pull out the red Emergency Stop button to the on position at both the ground and platform controls.
- 6 Raise the platform approximately 8 feet / 2.4 m from the ground.
- 7 Place a lifting strap from an overhead crane under the platform. Support the platform. Do not apply any lifting pressure.

NOTICE Component damage hazard. The platform railings can be damaged if they are used to lift the platform. Do not attach the lifting strap to the platform railings.

- 8 Inspect the center chassis area for burnt, chafed and pinched cables.
- 9 Open the battery tray cover.
- 10 Inspect the battery tray for burnt, chafed and pinched cables.
- 11 Close the battery tray cover.
- 12 Remove the strap from the platform.
- 13 Lower the platform to the stowed position and turn the machine off.

REV D

CHECKLIST B PROCEDURES

B-3 Inspect the Tires and Wheels (including castle nut torque)



Genie specifications require that this procedure be performed every 250 hours or quarterly, whichever comes first.

Maintaining the tires and wheels in good condition is essential to safe operation and good performance. Tire and/or wheel failure could result in a machine tip-over. Component damage may also result if problems are not discovered and repaired in a timely fashion.

- 1 Check the tire surface and sidewalls for cuts, cracks, punctures and unusual wear.
- 2 Check each wheel for damage, bends and cracks.
- 3 Remove the cotter pin and check each castle nut for proper torque. Refer to Section 2, *Specifications*.

Note: Always replace the cotter pin with a new one when removing the castle nut or when checking the torque of the castle nut.

- 4 Install a new cotter pin. Bend the cotter pin to lock it in place.

B-4 Check the Lifting Chain Adjustments



Genie specifications require that this procedure be performed every 250 hours or quarterly, whichever comes first.

Maintaining proper adjustment of the lifting chains is essential to safe machine operation. Failure to maintain proper chain adjustment could result in an unsafe operating condition and may cause component damage.

- 1 Fully lower the platform and measure the maximum height of the machine.
- ⦿ Result: The machine is within specification. Refer to Section 2, *Specifications*.
 - ⊗ Result: The machine is not within specification. Adjust the chains. Refer to Repair procedure 3-3, *How to Adjust the Lifting Chains*.

CHECKLIST B PROCEDURES

REV D

B-5 Clean and Lubricate the Columns



Genie specifications require that this procedure be performed every 250 hours or quarterly, whichever comes first.

Clean and properly lubricated columns are essential to good machine performance and safe operation. Extremely dirty conditions may require that the columns be cleaned and lubricated more often.

- 1 Raise the platform to the maximum height.
- 2 Place a lifting strap from an overhead crane under the platform. Support the platform. Do not apply any lifting pressure.

NOTICE Component damage hazard. The platform railings can be damaged if they are used to lift the platform. Do not attach the lifting strap to the platform railings.

- 3 Visually inspect the inner and outer channels of the columns for debris or foreign material. If necessary, use a mild cleaning solvent to clean the columns.

WARNING Bodily injury hazard. This procedure will require the use of additional access equipment. Do not place ladders or scaffold on or against any part of the machine. Performing this procedure without the proper skills and tools could result in death or serious injury. Dealer service is strongly recommended.

- 4 If needed, apply a generous amount of Boe-lube wax to the inside and outside channels of each column.

B-6 Adjust the Sequencing Cables



Genie specifications require that this procedure be performed every 250 hours or quarterly, whichever comes first.

Maintaining proper adjustment of the sequencing cables is essential for safe machine operation. An unsafe working condition exists if the sequencing cables are improperly adjusted. A frequent check allows the inspector to identify changes in the sequencing cables operating condition that might indicate damage.

- 1 Fully lower the platform.
- 2 Locate the compression spring on each sequencing cable.

Note: The spring is located between the nylock nut and the upper sequencing bracket.

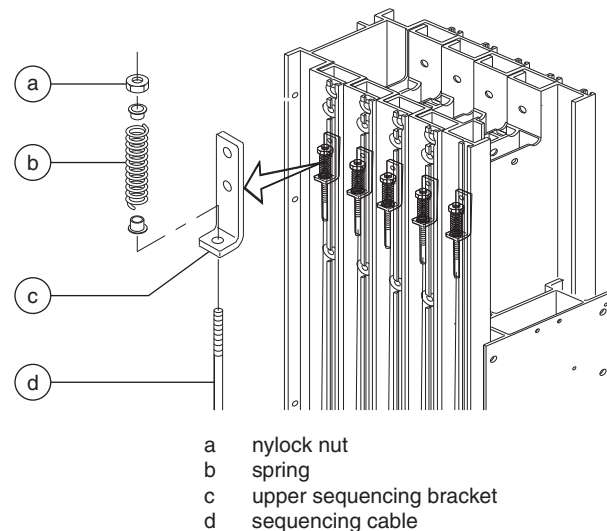

REV D

CHECKLIST B PROCEDURES

- 3 Confirm proper tension of each sequencing cable by measuring the height of the spring between the nylock nut and the upper sequencing bracket.

☉ Result: The measurement is within specification. Proceed to step 7.

☒ Result: The measurement is not within specification. Proceed to step 4.

Sequencing cable spring specification

Measurement, compressed	$15/16$ inch 2.4 cm
-------------------------	------------------------

- 4 Adjust the spring compressed length by turning the nylock nut clockwise to decrease the spring length or counterclockwise to increase the spring length.

NOTICE Component damage hazard. Do not compress the spring to less than specification.

- 5 Raise and lower the platform through three complete cycles.
- 6 Repeat this procedure beginning with step 3.
- 7 Repeat steps 3 through 5 for each sequencing cable as required.

B-7 Test the Emergency Stop

Genie specifications require that this procedure be performed every 250 hours or quarterly, whichever comes first.

A properly functioning Emergency Stop is essential for safe machine operation. An improperly operating red Emergency Stop button will fail to shut off power and stop all machine functions, resulting in a hazardous situation.

Note: As a safety feature, selecting and operating the ground controls will override the platform controls, except the platform red Emergency Stop button.

- 1 Turn the key switch to ground control and pull out the red Emergency Stop button to the on position at both the ground and platform controls.
- 2 Push in the red Emergency Stop button at the ground controls to the off position.

☉ Result: No machine functions should operate.

3 Turn the key switch to platform control and pull out the red Emergency Stop button to the on position at both the ground and platform controls.

4 Push down the red Emergency Stop button at the platform controls to the off position.

☉ Result: No machine functions should operate.

Note: The red Emergency Stop button at the ground controls will stop all machine operation, even if the key switch is switched to platform control.

CHECKLIST B PROCEDURES

REV D

B-8 Test the Key Switch

Genie specifications require that this procedure be performed every 250 hours or quarterly, whichever comes first.

Proper key switch action and response is essential to safe machine operation. The machine can be operated from the ground or platform controls and the activation of one or the other is accomplished with the key switch. Failure of the key switch to activate the appropriate control panel could cause a hazardous operating situation.

Note: Perform this procedure from the ground using the platform controls. Do not stand in the platform.

- 1 Pull out the red Emergency Stop button to the on position at both the ground and platform controls.
- 2 Turn the key switch to **platform control**.
- 3 Check the platform up/down function from the **ground controls**.
- ⊙ Result: The machine functions should **not** operate.
- 4 Turn the key switch to **ground control**.
- 5 Check the machine functions from the **platform controls**.
- ⊙ Result: The machine functions should **not** operate.
- 6 Turn the key switch to the off position.
- 7 Test the machine functions from the ground and platform controls.
- ⊙ Result: No machine functions should operate.

B-9 Test the Automotive-style Horn (if equipped)

Genie specifications require that this procedure be performed every 250 hours or quarterly, whichever comes first.

The horn is activated at the platform controls and sounds at the ground as a warning to ground personnel. An improperly functioning horn will prevent the operator from alerting ground personnel of hazards or unsafe conditions.

- 1 Turn the key switch to platform control and pull out the red Emergency Stop button to the on position at both the ground and platform controls.
- 2 Push down the horn button at the platform controls.
- ⊙ Result: The horn should sound.

REV D

CHECKLIST B PROCEDURES

B-10 Inspect the Voltage Inverter (if equipped)

Genie specifications require that this procedure be performed every 250 hours or quarterly, whichever comes first.

The inverter is activated whenever the power is on, and an electrical tool is connected to the inverter and turned on.

- 1 Inspect the inverter plug and pigtail for damage or excessive insulation wear. Replace as required.
- 2 Turn the key switch to the on position and pull out the red Emergency Stop button to the on position at both the ground and platform controls.

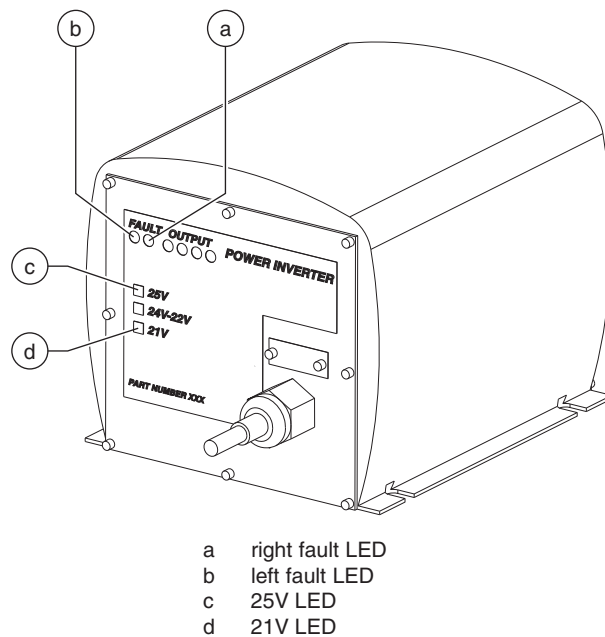

- 3 Connect an appropriate power tool to the inverter. Activate the tool.
 - ☉ Result: The power tool should operate. There may be a brief (0.5 second) delay if the power tool has not been used in the previous 10 minutes.
 - ☒ If the left fault LED (REV_POL) is illuminated, the inverter is connected to batteries with the incorrect polarity. Correct the polarity issue with the red wire to battery positive and the black wire to battery negative. The inverter will then operate correctly and begin supplying AC power.
 - ☒ If the right fault LED (123) blinks **one time**, the power draw is too high. The tool being used requires too much power to operate or is being used at or near the limit of the inverter for an extended period of time. Reduce the power draw. The inverter will then operate correctly and begin supplying AC power.
 - ☒ If the right fault LED (123) blinks **two times**, the Ground Fault Interrupt (GFI) has been activated. A short circuit or partial short exists between the AC hot and ground in the tool or outlet. Check the tool for burnt, chafed, corroded and loose wires, and inspect the tool for internal moisture. Correct the short circuit or moisture issue OR inspect the wiring in the power-to-platform box. The inverter will then operate correctly and begin supplying AC power.
 - ☒ If right fault LED (123) blinks **three times**, the inverter is overheated. Allow the inverter to cool. The inverter will then operate correctly and begin supplying AC power.
 - ☒ If the battery 25 volt fault LED (25V) blinks one time, the battery voltage is over 30V. Operate the machine to lower the voltage level. The inverter will then operate correctly and begin supplying AC power.
 - ☒ If the battery 21 volt fault LED (21V) blinks one time, the battery voltage is less than 20V DC. The inverter will continue to operate until the battery voltage falls to 17.8V DC.

CHECKLIST B PROCEDURES

REV D

B-11 Test the Drive Brakes



Genie specifications require that this procedure be performed every 250 hours or quarterly, whichever comes first.

Proper brake action is essential to safe machine operation. The drive brake function should operate smoothly, free of hesitation, jerking and unusual noise. Hydraulically-released individual wheel brakes can appear to operate normally when not fully operational.

Note: Perform this procedure with the machine on a firm, level surface that is free of obstructions.

Note: Be sure the platform extension deck is fully retracted and the platform is in the stowed position.

- 1 Mark a test line on the ground for reference.
- 2 Turn the key switch to platform control and pull out the red Emergency Stop button to the on position at both the ground and platform controls.
- 3 Lower the platform to the stowed position.
- 4 Press the drive function select button.
- 5 Choose a point on the machine; i.e., contact patch of a tire, as a visual reference for use when crossing the test line.

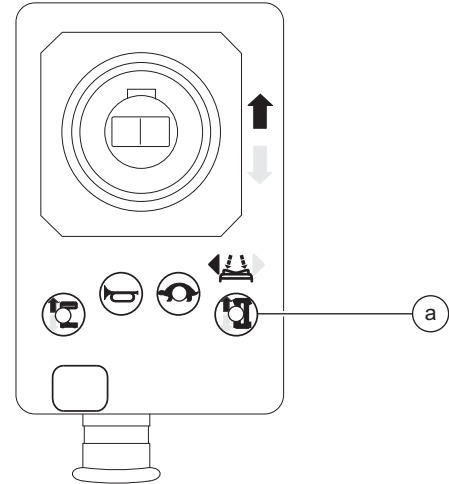

a drive function select button BN8

- 6 Bring the machine to top drive speed before reaching the test line. Release the function enable switch or the joystick when your reference point on the machine crosses the test line.
- 7 Measure the distance between the test line and your machine reference point. Refer to Section 2, *Specifications*.

Note: The brakes must be able to hold the machine on any slope it is able to climb.

REV D

CHECKLIST B PROCEDURES

B-12 Test the Drive Speed - Stowed Position



Genie specifications require that this procedure be performed every 250 hours or quarterly, whichever comes first.

Proper drive functions are essential to safe machine operation. The drive function should respond quickly and smoothly to operator control. Drive performance should also be free of hesitation, jerking and unusual noise over the entire proportionally controlled speed range.

Note: Perform this procedure with the machine on a firm, level surface that is free of obstructions.

- 1 Create start and finish lines by marking two lines on the ground 40 feet / 12.2 m apart.
- 2 Turn the key switch to platform control and pull out the red Emergency Stop button to the on position at both the ground and platform controls.
- 3 Lower the platform to the stowed position.
- 4 Press the drive function select button.
- 5 Choose a point on the machine; i.e., contact patch of a tire, as a visual reference for use when crossing the start and finish lines.

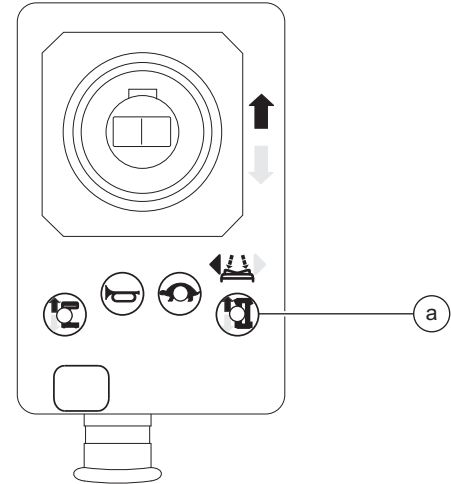

a drive function select button BN8

- 6 Bring the machine to top drive speed before reaching the start line. Begin timing when your reference point on the machine crosses the start line.
- 7 Continue at full speed and note the time when your reference point on the machine passes over the finish line. Refer to Section 2, *Specifications*.

CHECKLIST B PROCEDURES

REV D

B-13 Test the Drive Speed - Raised Position



Genie specifications require that this procedure be performed every 250 hours or quarterly, whichever comes first.

Proper drive functions are essential to safe machine operation. The drive function should respond quickly and smoothly to operator control. Drive performance should also be free of hesitation, jerking and unusual noise over the entire proportionally controlled speed range.

Note: Perform this procedure with the machine on a firm, level surface that is free of obstructions.

- 1 Create start and finish lines by marking two lines on the ground 40 feet / 12.2 m apart.
- 2 Turn the key switch to platform control and pull out the red Emergency Stop button to the on position at both the ground and platform controls.
- 3 Press the lift function select button.
- 4 Press and hold the function enable switch on the joystick.
- 5 Raise the platform approximately 4 feet / 1.2 m from the ground.
- 6 Press the drive function select button.

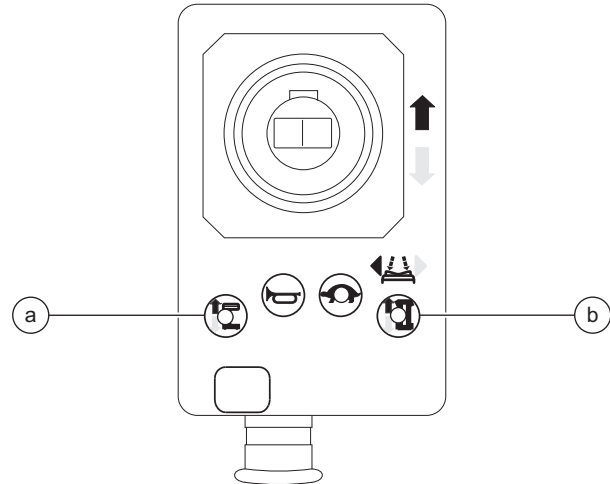

- a lift function select button BN9
b drive function select button BN8

- 7 Choose a point on the machine; i.e., contact patch of a tire, as a visual reference for use when crossing the start and finish lines.
- 8 Bring the machine to top drive speed before reaching the start line. Begin timing when your reference point on the machine crosses the start line.
- 9 Continue at full speed and note the time when your reference point on the machine passes over the finish line. Refer to Section 2, *Specifications*.

REV D

CHECKLIST B PROCEDURES

B-14 Test the Slow Drive Speed



Genie specifications require that this procedure be performed every 250 hours or quarterly, whichever comes first.

Proper drive functions are essential to safe machine operation. The drive function should respond quickly and smoothly to operator control. Drive performance should also be free of hesitation, jerking and unusual noise over the entire proportionally controlled speed range.

Note: Perform this procedure with the machine on a firm, level surface that is free of obstructions.

- 1 Create start and finish lines by marking two lines on the ground 40 feet / 12.2 m apart.
- 2 Turn the key switch to platform control and pull out the red Emergency Stop button to the on position at both the ground and platform controls.
- 3 Lower the platform to the stowed position.
- 4 Press the slow speed select button.
- 5 Choose a point on the machine; i.e., contact patch of a tire, as a visual reference for use when crossing the start and finish lines.

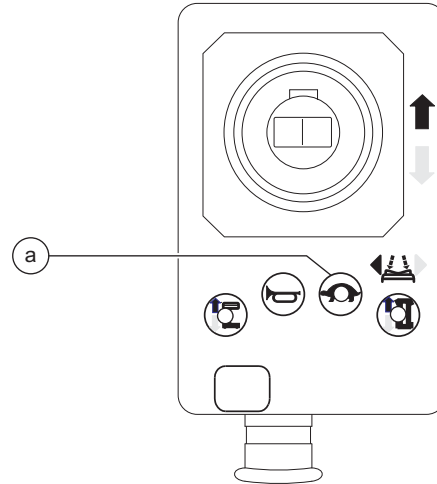

a slow speed select button BN6

- 6 Bring the machine to top drive speed before reaching the start line. Begin timing when your reference point on the machine crosses the start line.
- 7 Continue at full speed and note the time when your reference point on the machine passes over the finish line. Refer to Section 2, *Specifications*.

CHECKLIST B PROCEDURES

REV D

B-15**Test the Motion Alarm
(if equipped)**

Genie specifications require that this procedure be performed every 250 hours or quarterly, whichever comes first.

Alarms are used to alert operators and ground personnel of machine proximity and motion. The motion alarm is located in the ground control box and, when activated, will sound at 60 beeps per minute.

- 1 Turn the key switch to ground control and pull out the red Emergency Stop button to the on position at both the ground and platform controls.
- 2 Raise the platform approximately 1 foot / 0.3 m.
 - ⦿ Result: When raising the platform, the motion alarm should sound.
- 3 Lower the platform to the stowed position.
 - ⦿ Result: When lowering the platform, the motion alarm should sound.
- 4 Turn the key switch to platform controls.
- 5 Press the lift function select button.
- 6 Press and hold the function enable switch on the joystick. Move the joystick off center, hold for a moment and then release it. Move the joystick off center in the opposite direction, hold for a moment and then release it.
 - ⦿ Result: The motion alarm should sound when the joystick is moved off center in either direction.
- 7 Press the drive function select switch.
- 8 Press and hold the function enable switch on the joystick. Move the joystick off center, hold for a moment and then release it. Move the joystick off center in the opposite direction, hold for a moment and then release it.
 - ⦿ Result: The motion alarm should sound when the joystick is moved off center in either direction.
- 9 Press and hold the function enable switch on the joystick. Press and hold the thumb rocker switch for a moment to the left position and then release it. Press and hold the thumb rocker switch for a moment to the right position and then release it.
 - ⦿ Result: The motion alarm should sound when the rocker switch is moved off center in either direction.

REV D

CHECKLIST B PROCEDURES

B-16 Test the Flashing Beacons (if equipped)

Genie specifications require that this procedure be performed every 250 hours or quarterly, whichever comes first.

Flashing beacons are used to alert operators and ground personnel of machine proximity and motion. The flashing beacons are located on both sides of the mast.

- 1 Turn the key switch to ground control and pull out the red Emergency Stop button to the on position at both the ground and platform controls.
 - ⦿ Result: The beacons should flash.
- 2 Turn the key switch to platform controls.
 - ⦿ Result: The beacons should flash.

B-17 Perform Hydraulic Oil Analysis



Genie specifications require that this procedure be performed every 250 hours or quarterly, whichever comes first.

Replacement or testing of the hydraulic oil is essential for good machine performance and service life. Dirty oil may cause the machine to perform poorly and continued use may cause component damage. Extremely dirty conditions may require oil changes to be performed more often.

Before replacing the hydraulic oil, the oil may be tested by an oil distributor for specific levels of contamination to verify that changing the oil is necessary.

If the hydraulic oil is not replaced at the two year inspection, test the oil quarterly. Replace the oil when it fails the test. See E-1, *Test or Replace the Hydraulic Oil*.

CHECKLIST B PROCEDURES

REV D

B-18**Inspect the Breather Cap**

Genie specifications require that this procedure be performed every 250 hours or quarterly, whichever comes first.

A free-breathing hydraulic tank cap is essential for good machine performance and service life. A dirty or clogged cap may cause the machine to perform poorly. Extremely dirty conditions may require that the cap be inspected more often.

- 1 Remove the breather cap from the hydraulic tank.
- 2 Check for proper venting.
 - ⦿ Result: Air passes through the breather cap.
 - ✗ Result: If air does not pass through the cap, clean or replace the cap. Proceed to step 3.

Note: When checking for positive tank cap venting, air should pass freely through the cap.

- 3 Using a mild solvent, carefully wash the cap venting system. Dry using low pressure compressed air. Repeat step 2.
- 4 Install the breather cap onto the hydraulic tank.

Checklist C Procedures

REV D

C-1 Grease the Platform Overload Mechanism (if equipped)



Genie specifications require that this procedure be performed every 500 hours or 6 months, whichever comes first. Perform this procedure more often if dusty conditions exist.

Application of lubrication to the platform overload mechanism is essential to safe machine operation. Continued use of an improperly greased platform overload mechanism could result in the system not sensing an overloaded platform condition and will result in component damage.

- 1 Locate the grease fittings on each pivot pin of the platform overload assembly.
- 2 Thoroughly pump grease into each grease fitting using a multi-purpose grease.

C-2 Replace the Hydraulic Tank Breather Cap - Models with Optional Hydraulic Oil



Genie specifications require that this procedure be performed every 500 hours or six months, whichever comes first OR when the machine fails to lift the maximum rated load.

The hydraulic tank is a vented-type tank. The breather cap has an internal air filter that can become clogged or, over time, can deteriorate. If the breather cap is faulty or improperly installed, impurities can enter the hydraulic system which may cause component damage. Extremely dirty conditions may require that the cap be inspected more often.

- 1 Remove and discard the hydraulic tank breather cap.
- 2 Install and new cap onto the tank.

CHECKLIST C PROCEDURES

REV D

C-3

Test the Platform Overload System (if equipped)



Genie specifications require that this procedure be performed every 500 hours or 6 months, whichever comes first.

Testing the platform overload system regularly is essential to safe machine operation. Continued use of an improperly operating platform overload system could result in the system not sensing an overloaded platform condition. Machine stability could be compromised resulting in the machine tipping over.

Note: Perform this procedure with the machine on a firm, level surface.

- 1 Turn the key switch to platform control and pull out the red Emergency Stop button to the on position at both the ground and platform controls.
- 2 Determine the maximum platform capacity. Refer to the machine serial plate.
- 3 Using a suitable lifting device, place an appropriate test weight equal to the maximum platform capacity in the center of the platform floor.
 - ⊙ Result: The diagnostic display at the ground controls will show two flat bars and a blinking light, indicating a normal condition, and the diagnostic display at the platform controls will show the battery condition. Refer to Repair procedure 1-3, *How to Determine the Battery Voltage*.
 - ✗ Result: The diagnostic display will show 'OL' at both the ground and platform controls. The platform overload system is not operating properly. Refer to Repair Procedure 11-1, *Calibrate the Platform Overload System (if equipped)*.
- 4 Add an additional weight to the platform not to exceed 20% of the maximum rated load. Refer to the machine serial plate.
 - ⊙ Result: The diagnostic display will show 'OL' at both the ground and platform controls. The platform overload system is operating properly.
 - ✗ Result: The diagnostic display at the ground controls will show two flat bars and a blinking light and the diagnostic display at the platform controls will show the battery condition. The platform overload system is not operating properly. Refer to Repair Procedure 11-1, *Calibrate the Platform Overload System (if equipped)*.
- 5 Test all machine functions from the platform controls.
 - ⊙ Result: All platform control functions should not operate.

REV D

CHECKLIST C PROCEDURES

- 6 Turn the key switch to ground control.
- 7 Test all machine functions from the ground controls.
 - ⦿ Result: All ground control functions should not operate.
- 8 Lift the test weight off the platform floor using a suitable lifting device. Turn the key switch to the off position.
- 9 Turn the key switch to ground control.
 - ⦿ Result: The diagnostic display at the ground controls will show two flat bars and a blinking light, indicating a normal condition, and the diagnostic display at the platform controls will show the battery condition.
 - ⊗ Result: The diagnostic display will show 'OL' at both the ground and platform controls. The platform overload system is not operating properly. Refer to Repair Procedure 11-1, *Calibrate the Platform Overload System (if equipped)*.
- 10 Test all machine functions from the ground controls.
 - ⦿ Result: All ground control functions should operate normally.
- 11 Turn the key switch to platform control.
- 12 Test all machine functions from the platform controls.
 - ⦿ Result: All platform control functions should operate.

Note: If the platform overload system is not operating properly, refer to Repair Procedure 11-1, *Calibrate the Platform Overload System (if equipped)*.

Checklist D Procedures

REV D

D-1 Inspect the Mast Assembly for Wear



Genie specifications require that this procedure be performed every 1000 hours or annually, whichever comes first.

Detection of excessive or unusual wear in the mast assembly is essential for safe machine operation. An unsafe working condition exists if the mast assembly has excessive wear and/or does not operate smoothly, free of hesitation and binding.

- 1 Remove the mast covers.

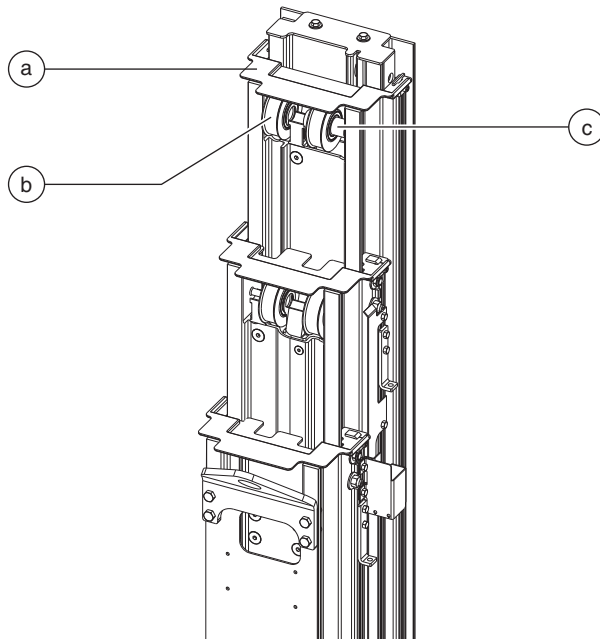

GR-15 shown

- a mast cover
- b idler wheel
- c spacer

- 2 Raise the platform until approximately 4 inches / 10 cm of each column is visible.
- 3 **GR-12 and GR-15:** Visually inspect the top of each column for clearance between the roller wheels and the adjacent column surface.
GR-20: Visually inspect the top of each column for clearance between the slider block and the adjacent column surface.

- ⊙ **Result:** There should be an equal amount of distance between the roller wheel/slider block and the column on each side.

Note: If mast inspection results in a measurement that is not within specification, refer to Repair procedure 3-2, *How to Adjust the Glide Pads*.

- 4 Loosen but do not remove the adjustment nut on the sequencing cable located at the top of the first column.
- 5 Raise the platform approximately 3 feet / 1 m above the top of the drive chassis.
- 6 Place a jack stand on the top of the battery cover, centered under the platform. Adjust the jack stand height to 24 inches / 60 cm.
- 7 Lower the platform onto the jack stand just enough to take the weight off the lifting chains.

⚠ WARNING Crushing hazard. Keep hands clear of the jack stand when lowering the platform.

REV D

CHECKLIST D PROCEDURES

8 Inspect each idler wheel for the following:

- Excessive wear on the side flanges
- Unusual wear
- Movement side to side in excess of 0.040 inch / 1 mm
- Any wheel movement front to back

Note: If idler wheel inspection results in a condition that is not within specification, refer to Repair procedure 3-1, *How to Assemble the Mast*.

9 **GR-20:** Inspect each wear pad for the following:

- Excessive or unusual wear

Note: If a wear pad displays excessive or unusual wear, refer to Repair procedure 3-1, *How to Assemble the Mast*.

10 Raise the platform slightly and remove the jack stand. Lower the platform to the stowed position.

11 Install the mast covers and adjust the sequencing cable. See B-6, *Adjust the Sequencing Cables*.

D-2

Inspect and Lubricate the Lifting Chains



Genie specifications require that this procedure be performed every 1000 hours or annually, whichever comes first.

Lubricated chains are essential to good machine performance and safe operation. Extremely dirty conditions may require that the chains be cleaned and lubricated more often.

- 1 Thoroughly inspect the lifting chains. Refer to Repair Procedure 3-3, *How to Inspect the Lifting Chains*.
- 2 Raise the platform to the maximum height.
- 3 Place a lifting strap from an overhead crane under the platform. Support the platform. Do not apply any lifting pressure.

NOTICE

Component damage hazard. The platform railings can be damaged if they are used to lift the platform. Do not attach the lifting strap to the platform railings.

- 4 Lubricate each chain with a dry-type spray lubricant.

WARNING

Bodily injury hazard. This procedure will require the use of additional access equipment. Do not place ladders or scaffold on or against any part of the machine. Performing this procedure without the proper skills and tools could result in death or serious injury. Dealer service is strongly recommended.

CHECKLIST D PROCEDURES

REV D

D-3 Replace the Hydraulic Tank Return Filter



Genie specifications require that this procedure be performed every 1000 hours or annually, whichever comes first.

Replacement of the hydraulic tank return filter is essential for good machine performance and service life. A dirty or clogged filter may cause the machine to perform poorly and continued use may cause component damage. Extremely dirty conditions may require that the filter be replaced more often.

CAUTION Burn hazard. Beware of hot oil. Contact with hot oil may cause severe burns.

Note: The hydraulic tank return filter is mounted on the function manifold next to the hydraulic power unit.

- 1 Clean the area around the oil filter. Remove the filter with an oil filter wrench.
- 2 Apply a thin layer of oil to the new oil filter gasket.
- 3 Install the new filter and tighten it securely by hand.

- 4 Use a permanent ink marker to write the date and number of hours from the hour meter onto the filter.
- 5 Turn the key switch to ground control and pull out the red Emergency Stop button to the on position at both the ground and platform controls.
- 6 Activate and hold the platform up toggle switch.
- 7 Inspect the filter and related components to be sure that there are no leaks.
- 8 Clean up any oil that may have spilled.

Torque specifications

Hydraulic tank drain plug, dry	40 in-lbs 4.5 Nm
Hydraulic tank drain plug, lubricated	30 in-lbs 3.4 Nm

Checklist E Procedure

REV B

E-1 Test or Replace the Hydraulic Oil



Genie specifications require that this procedure be performed every 2000 hours or every two years, whichever comes first.

Replacement or testing of the hydraulic oil is essential for good machine performance and service life. Dirty oil may cause the machine to perform poorly and continued use may cause component damage. Extremely dirty conditions may require oil changes to be performed more often.

Note: Before replacing the hydraulic oil, the oil may be tested by an oil distributor for specific levels of contamination to verify that changing the oil is necessary. **If the hydraulic oil is not replaced at the two year inspection, test the oil quarterly. Replace the oil when it fails the test.**

Note: Perform this procedure with the platform in the stowed position.

- 1 Disconnect the battery pack from the machine.

WARNING Electrocutation/burn hazard. Contact with hot or live circuits could result in death or serious injury. Remove all rings, watches and other jewelry.

- 2 Open the power unit module tray.

- 3 Tag and disconnect the hydraulic tank return hard line from the hydraulic filter head and remove the hard line from the tank. Cap the fitting on the filter head.
- 4 Tag and disconnect the hydraulic pump inlet hard line and remove the hard line from the tank. Cap the fitting on the pump.
- 5 Remove the hydraulic tank retaining fasteners and remove the hydraulic tank from the machine.
- 6 Drain all of the oil into a suitable container. Refer to Section 2, *Specifications*, for capacity information.

WARNING Bodily injury hazard. Spraying hydraulic oil can penetrate and burn skin. Loosen hydraulic connections very slowly to allow the oil pressure to dissipate gradually. Do not allow oil to squirt or spray.

- 7 Clean up any oil that may have spilled. Properly discard the used oil.
- 8 Clean the inside of the hydraulic tank using a mild solvent. Allow the tank to dry completely.
- 9 Install the hydraulic tank and install and tighten the hydraulic tank retaining fasteners. Torque to specification.

Torque specifications

Hydraulic tank retaining fasteners, dry	35 in-lbs 4 Nm
Hydraulic tank retaining fasteners, lubricated	26 in-lbs 2.9 Nm

CHECKLIST E PROCEDURE

REV B

- 10 Install the hydraulic pump inlet hard line into the tank. Install the fitting onto the pump and torque to specification. Refer to Section 2, *Specifications*.
- 11 Install the hydraulic pump return hard line into the tank. Install the fitting onto the hydraulic filter head and torque to specification. Refer to Section 2, *Specifications*.
- 12 Fill the tank with hydraulic oil until the fluid is at the FULL indicator on the hydraulic tank. Do not overfill.
- 13 Activate the pump to fill the hydraulic system with oil and bleed the system of air.

NOTICE Component damage hazard. The pump can be damaged if operated without oil. Be careful not to empty the hydraulic tank while in the process of filling the hydraulic system. Do not allow the pump to cavitate.

- 14 Repeat steps 12 through 13 until the hydraulic system and tank are both full.

Repair Procedures



Observe and Obey:

- ☑ Repair procedures shall be completed by a person trained and qualified on the repair of this machine.
- ☑ Immediately tag and remove from service a damaged or malfunctioning machine.
- ☑ Repair any machine damage or malfunction before operating the machine.

Before Repairs Start:

- ☑ Read, understand and obey the safety rules and operating instructions in the appropriate operator's manual on your machine.
- ☑ Be sure that all necessary tools and parts are available and ready for use.
- ☑ Use only Genie approved replacement parts.
- ☑ Read each procedure completely and adhere to the instructions. Attempting shortcuts may produce hazardous conditions.
- ☑ Unless otherwise specified, perform each repair procedure with the machine in the following configuration:
 - Machine parked on a firm, level surface
 - Platform in the stowed position
 - Key switch in the off position with the key removed
 - The red Emergency Stop button in the off position at both ground and platform controls
 - Wheels chocked
 - All external AC power supply disconnected from the machine

About This Section

Most of the procedures in this section should only be performed by a trained service professional in a suitably equipped workshop. Select the appropriate repair procedure after troubleshooting the problem.

Perform disassembly procedures to the point where repairs can be completed. Then to re-assemble, perform the disassembly steps in reverse order.

Symbols Legend



Safety alert symbol—used to alert personnel to potential personal injury hazards. Obey all safety messages that follow this symbol to avoid possible injury or death.



Indicates an imminently hazardous situation which, if not avoided, will result in death or serious injury.



Indicates a potentially hazardous situation which, if not avoided, could result in death or serious injury.



Indicates a potentially hazardous situation which, if not avoided, may cause minor or moderate injury.



Indicates a potentially hazardous situation which, if not avoided, may result in property damage.

⦿ Indicates that a specific result is expected after performing a series of steps.

⊗ Indicates that an incorrect result has occurred after performing a series of steps.

Platform Controls

REV E

The platform controls, used to operate the machine from the platform or while standing on the ground, can also be used to tune the performance of the machine.

Moving the joystick or activating a button sends a signal to the Electronic Control Module (ECM). When the ECM is in the function mode, the platform controls are used to operate the various machine functions. When the ECM is in the speed tuning mode (PS is shown in the diagnostic display window) or software configuration mode (SC is shown in the diagnostic display window), the platform controls are used to adjust the function speed parameters or the machine configuration.

The platform controls consist of an electronic circuit board, joystick, alarm, buttons and LEDs.

For further information or assistance, consult the Genie Industries Service Department.

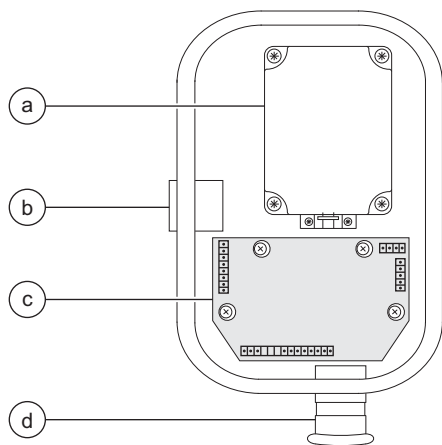

- a joystick controller JC1
- b alarm H1
- c platform controls circuit board U3
- d red Emergency Stop button P2

1-1 Circuit Boards

How to Remove the Platform Controls Circuit Board

- 1 Push in the red Emergency Stop button to the off position at both the ground and platform controls.
- 2 Remove the retaining fasteners securing the bottom to the platform control box. Open the control box.
- 3 Remove the ties securing the wire harness.
- 4 Remove the alarm and red Emergency Stop button from the platform control box.
- 5 Carefully disconnect the three wire harness connectors from the platform controls circuit board.

WARNING Electrocutation/burn hazard. Contact with electrically charged circuits could result in death or serious injury. Remove all rings, watches and other jewelry.

NOTICE Component damage hazard. Electrostatic discharge (ESD) can damage printed circuit board components. Maintain firm contact with a metal part of the machine that is grounded at all times when handling printed circuit boards OR use a grounded wrist strap.

- 6 Carefully remove the platform controls circuit board retaining fasteners.
- 7 Carefully remove the platform controls circuit board from the platform control box lid.

REV E

PLATFORM CONTROLS

1-2 Controller Adjustments

Platform lift speed, stowed drive speed, raised drive speed and slow drive speed are adjustable to compensate for wear in the hydraulic pump and drive motors.

The function speeds are determined by the percentage of total controller output.

For further information or assistance, consult the Genie Industries Service Department.

⚠ DANGER Tip-over hazard. Do not adjust the lift and/or drive speed higher than specified in this procedure. Setting the function speeds greater than specifications could cause the machine to tip over resulting in death or serious injury.

⚠ DANGER Tip-over hazard. This procedure must only be performed by a trained service professional. Attempting this procedure without the necessary skills could result in death or serious injury.

Note: Select a test area that is firm, level and free of obstructions.

How to Determine the Software Revision Level

- 1 Remove the platform controls from the platform.
- 2 Place the platform controls close to the diagnostic display on the power unit side of the machine.

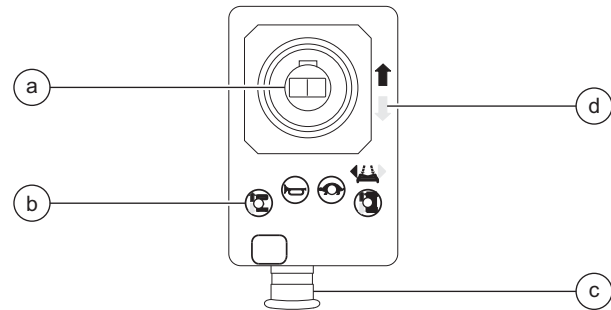

- a joystick controller JC1
- b lift function select button BN9
- c red Emergency Stop button P2
- d yellow arrow

- 3 Turn the key switch to platform control and pull out the red Emergency Stop button to the on position at both the ground and platform controls.
 - ⊙ Result: The diagnostic display at the platform controls will show the battery condition. See 1-3, *How to Determine the Battery Voltage*.
- 4 Press the lift function select button.
- 5 Slowly move the joystick in the direction indicated by the yellow arrow.
 - ⊙ Result: The software revision level will appear in the diagnostic display.
- 6 Push in the red Emergency Stop button to the off position at both the ground and platform controls and turn the key switch to the off position.

PLATFORM CONTROLS

REV E

How to Adjust the Lift Speed

⚠ DANGER Tip-over hazard. Do not adjust the lift and/or drive speed higher than specified in this procedure. Setting the function speeds greater than specifications could cause the machine to tip over resulting in death or serious injury.

⚠ DANGER Tip-over hazard. This procedure must only be performed by a trained service professional. Attempting this procedure without the necessary skills will result in death or serious injury.

- 1 Pull out the red Emergency Stop button to the on position at the ground controls.
- 2 Push in the red Emergency Stop button to the off position at the platform controls.
- 3 Turn the key switch to platform control.
- 4 At the platform controls, press and hold the lift function select and horn buttons and pull out the red Emergency Stop button to the on position.
- ⦿ Result: The diagnostic display will show "PS."
- 5 Release the lift function select and horn buttons.
- ⦿ Result: The diagnostic display will show the maximum lift speed percentage.
- 6 Press the lift function select button.

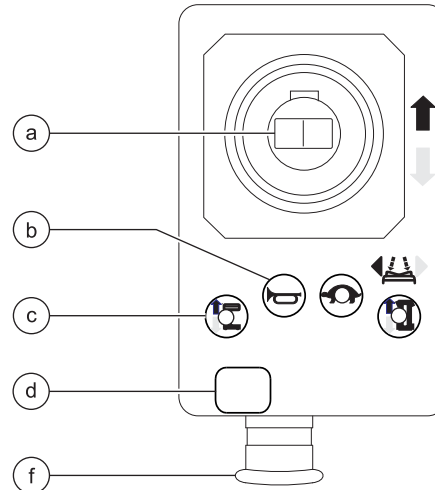

- a joystick controller JC1 with thumb steering rocker SW6
- b horn button BN5
- c lift function select button BN9
- d diagnostic display G8
- f red Emergency Stop button P2

- 7 Use the steering thumb rocker switch on the joystick to increase or decrease the maximum lift speed percentage. Refer to Section 2, *Specifications*, for function speeds.

- 8 Turn the key switch to the off position.

Note: Any change in software settings will not take effect until the key switch is turned to the off position.

REV E

PLATFORM CONTROLS

How to Adjust the Stowed Drive Speed

⚠ DANGER Tip-over hazard. Do not adjust the lift and/or drive speed higher than specified in this procedure. Setting the function speeds greater than specifications could cause the machine to tip over resulting in death or serious injury.

⚠ DANGER Tip-over hazard. This procedure must only be performed by a trained service professional. Attempting this procedure without the necessary skills will result in death or serious injury.

- 1 Pull out the red Emergency Stop button to the on position at the ground controls.
 - 2 Push in the red Emergency Stop button to the off position at the platform controls.
 - 3 Turn the key switch to platform control.
 - 4 At the platform controls, press and hold the lift function select and horn buttons and pull out the red Emergency Stop button to the on position.
- ⦿ Result: The diagnostic display will show "PS."
- 5 Release the lift function select and horn buttons.
- ⦿ Result: The diagnostic display will show the maximum lift speed percentage.

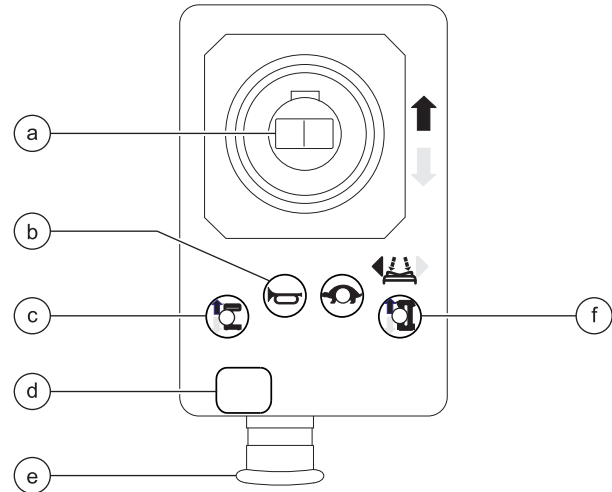

- a joystick controller JC1 with thumb steering rocker SW6
 b horn button BN5
 c lift function select button BN9
 d diagnostic display G8
 e red Emergency Stop button P2
 f drive function select button BN8

- 6 Press the drive function select button.
- ⦿ Result: The diagnostic display will show the stowed drive speed percentage.
- 7 Use the steering thumb rocker switch on the joystick to increase or decrease the stowed drive speed percentage. Refer to Section 2, *Specifications*, for function speeds.
 - 8 Turn the key switch to the off position.

Note: Any change in software settings will not take effect until the key switch is turned to the off position.

PLATFORM CONTROLS

REV E

How to Adjust the Raised Drive Speed

⚠ DANGER Tip-over hazard. Do not adjust the lift and/or drive speed higher than specified in this procedure. Setting the function speeds greater than specifications could cause the machine to tip over resulting in death or serious injury.

⚠ DANGER Tip-over hazard. This procedure must only be performed by a trained service professional. Attempting this procedure without the necessary skills will result in death or serious injury.

- 1 Pull out the red Emergency Stop button to the on position at the ground controls.
 - 2 Push in the red Emergency Stop button to the off position at the platform controls.
 - 3 Turn the key switch to platform control.
 - 4 At the platform controls, press and hold the lift function select and horn buttons and pull out the red Emergency Stop button to the on position.
- ⦿ Result: The diagnostic display will show "PS."
- 5 Release the lift function select and horn buttons.
- ⦿ Result: The diagnostic display will show the maximum lift speed percentage.

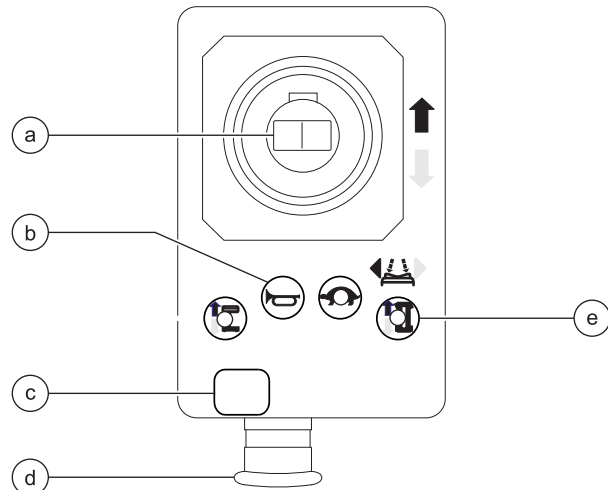

- a joystick controller JC1 with thumb steering rocker SW6
- b horn button BN5
- c diagnostic display G8
- d red Emergency Stop button P2
- e drive function select button BN8

- 6 Press the drive function select button.
 - 7 Press and hold the horn button.
- ⦿ Result: The diagnostic display will show the raised drive speed percentage.
- 8 Use the steering thumb rocker switch on the joystick to increase or decrease the maximum lift speed percentage. Refer to Section 2, *Specifications*, for function speeds.
 - 9 Turn the key switch to the off position.

Note: Any change in software settings will not take effect until the key switch is turned to the off position.

REV E

PLATFORM CONTROLS

How to Adjust the Slow Drive Speed

⚠ DANGER Tip-over hazard. Do not adjust the lift and/or drive speed higher than specified in this procedure. Setting the function speeds greater than specifications could cause the machine to tip over resulting in death or serious injury.

⚠ DANGER Tip-over hazard. This procedure must only be performed by a trained service professional. Attempting this procedure without the necessary skills will result in death or serious injury.

- 1 Pull out the red Emergency Stop button to the on position at the ground controls.
 - 2 Push in the red Emergency Stop button to the off position at the platform controls.
 - 3 Turn the key switch to platform control.
 - 4 At the platform controls, press and hold the lift function select and horn buttons and pull out the red Emergency Stop button to the on position.
- ⦿ Result: The diagnostic display will show "PS."
- 5 Release the lift function select and horn buttons.
- ⦿ Result: The diagnostic display will show the maximum lift speed percentage.

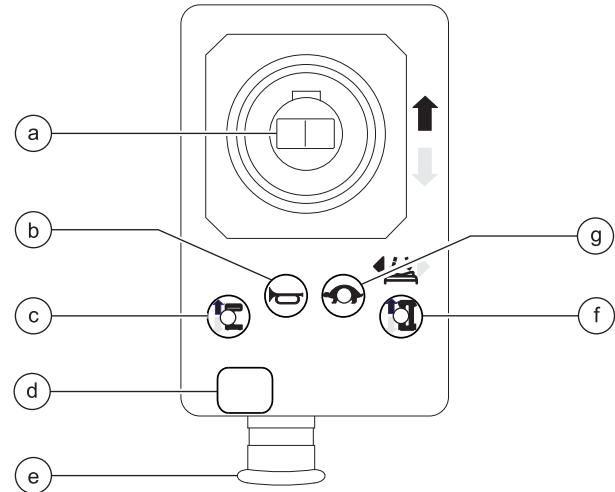

- a joystick controller JC1 with thumb steering rocker SW6
- b horn button BN5
- c lift function select button BN9
- d diagnostic display G8
- e red Emergency Stop button P2
- f drive function select button BN8
- g slow speed select button BN6

- 6 Press the drive function select button.
- ⦿ Result: The diagnostic display will show the stowed drive speed percentage.
- 7 Press and hold the slow speed select button.
- ⦿ Result: The diagnostic display will show the slow drive speed percentage.
- 8 Use the steering thumb rocker switch on the joystick to increase or decrease the stowed high torque drive speed percentage. Refer to Section 2, *Specifications*, for function speeds.
 - 9 Turn the key switch to the off position.

Note: Any change in software settings will not take effect until the key switch is turned to the off position.

PLATFORM CONTROLS

REV E

1-3 Software Configuration

The Electronic Control Module (ECM) contains programming for all configurations of the Genie Runabout. The machine can be adjusted to a different configuration using the buttons at the platform controls.

How to Determine the Software Configuration

- 1 Remove the platform controls from the platform.
- 2 Pull out the red Emergency Stop button to the on position at the ground controls.
- 3 Push in the red Emergency Stop button to the off position at the platform controls.
- 4 At the platform controls, press and hold the lift function select and speed select buttons, and pull out the red Emergency Stop button to the on position.
- ⦿ Result: The diagnostic display, at the platform controls and the ECM, will show "SC."
- 5 Release the lift function select and speed select buttons.
- ⦿ Result: The diagnostic display will show the current configuration.
- 6 Push in the red Emergency Stop button to the off position at both the ground and platform controls and turn the key switch to the off position.

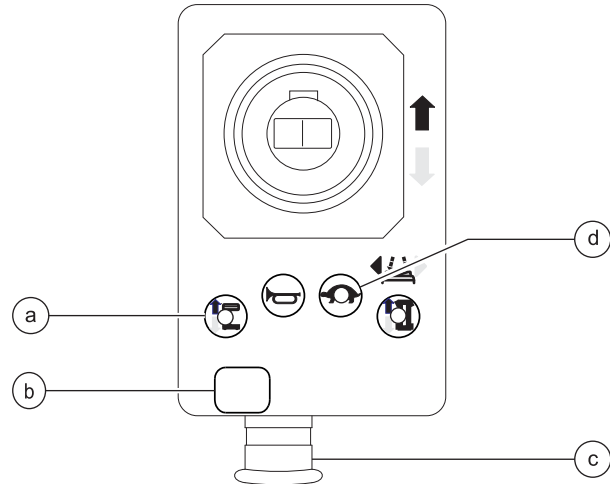

- a lift function select button BN9
- b diagnostic display
- c red Emergency Stop button P2
- d speed select button BN6

REV E

PLATFORM CONTROLS

How to Change the Software Configuration

- 1 Pull out the red Emergency Stop button to the on position at the ground controls.
 - 2 Push in the red Emergency Stop button to the off position at the platform controls.
 - 3 Turn the key switch to platform control.
 - 4 At the platform controls, press and hold the lift function select and speed select buttons, and pull out the red Emergency Stop button to the on position.
- ⊙ Result: The diagnostic display, at the platform controls and the ECM, will show "SC."
- 5 Release the lift function select and speed select buttons.
- ⊙ Result: The diagnostic display will show the current software configuration.
 - 6 Press the lift function select button.

⊙ Result: The 'tens' digit setting will be activated and the current 'tens' setting will flash in the diagnostic display. Use the steering thumb rocker switch on the joystick to increase or decrease the value. See 1-3, *Machine Configuration Code Chart* for configuration settings.
 - 7 Press and hold the lift function select button for a minimum of 3 seconds to set the 'tens' value.

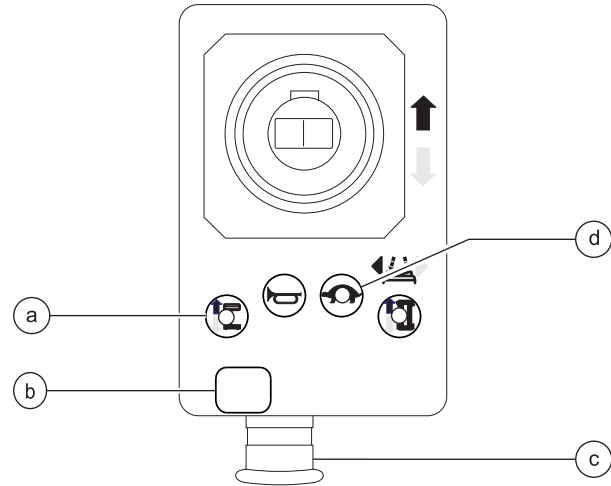

- a lift function select button BN9
 b diagnostic display
 c red Emergency Stop button P2
 d speed select button BN6

- 8 Press the slow speed select button.
- ⊙ Result: The 'ones' digit setting will be activated and the current 'ones' setting will flash in the diagnostic display. Use the steering thumb rocker switch on the joystick to increase or decrease the value. See 1-3, *Machine Configuration Code Chart* for configuration settings.
- 9 Press and hold the slow speed select button for a minimum of 3 seconds or until the 'ones' setting stops flashing.
 - 10 Turn the key switch to the off position.

Note: Any change in software settings will not take effect until the key switch is turned to the off position.

PLATFORM CONTROLS

REV E

Machine Configuration Code Chart (from serial number GR05-5001 to GR07-8706)

A mark in the four right columns indicates that the machine configuration, at left, includes this feature.

MACHINE CONFIGURATION CODES GR				
(ECMs with software revisins A0 to A4)				
Machine Function Code at Diagnostic Display	Non-slab Option	Motion Alarm	Lift/Drive Cut Out	Platform Overload
05	•			
23	•			•
25	•		•	•
26	•	•		•
27	•	•	•	•
29	•		•	
30	•	•	•	
31	•	•		

Machine Configuration Code Chart (after serial number GR07-8705 and from QS09-101)

A mark in the four right columns indicates that the machine configuration, at left, includes this feature.

MACHINE CONFIGURATION CODES GR • QSR • QSW				
(ECMs with software revisions A5 and higher)				
Machine Function Code at Diagnostic Display	Non-slab Option	Motion Alarm	Lift/Drive Cut Out	Platform Overload
05	•		•	
23	•		•	•
25	•		•	•
26	•	•	•	•
27	•	•	•	•
29	•		•	
30	•	•	•	
31	•	•	•	

Machine Option / Feature Definitions

Non-slab Option: For the GR to function correctly, each model is configured with this option.

Motion Alarm: The motion alarm will sound when operating any function.

Lift/Drive Cut Out: In addition to an alarm sounding, lift and drive functions are disabled when the platform is raised above the down limit switch and the incline of the chassis exceeds the rating on the serial plate. Configured on all machines.

Platform Overload: When the platform overload limit switch is tripped, signaling an overload condition in the platform, all machine functions are disabled. The additional weight must be removed from the platform and the power cycled from off to on before any function can be resumed. Required for CE models.

Battery Drain Alarm: When the machine is turned on and in the stowed position, and no function is activated for 2 minutes, an alarm will sound once every 3 seconds.

When this option is configured, a dot in the diagnostic display window will remain continuously illuminated when the ECM is in the 'SC' mode OR when the platform up function is activated.

REV E

PLATFORM CONTROLS

How to Activate the Battery Drain Alarm Option

- 1 Pull out the red Emergency Stop button to the on position at the ground controls.
- 2 Push in the red Emergency Stop button to the off position at the platform controls.
- 3 Turn the key switch to platform control.
- 4 At the platform controls, press and hold the lift function select and speed select buttons, and pull out the red Emergency Stop button to the on position.
- ⊙ Result: The diagnostic display, at the platform controls and the ECM, will show "SC."
- 5 Release the lift function select and speed select buttons.
- ⊙ Result: The diagnostic display will show the current software configuration.
- 6 Press the slow speed select button.
- ⊙ Result: The 'ones' digit setting will be activated and the current 'ones' setting will flash in the diagnostic display.
- 7 Press the horn button.
- ⊙ Result: A dot, located at the lower right of the diagnostic display window, will become illuminated. This indicates that the battery drain alarm option has been activated.
- 8 Press and hold the speed select button for a minimum of 3 seconds or until the 'ones' setting stops flashing.
- 9 Turn the key switch to the off position.

Note: To deactivate the battery drain alarm option on a machine which has the option activated, repeat this procedure. When the ECM is in the 'SC' mode and the option is deactivated, there will not be an illuminated dot in the diagnostic display window.

How to Determine the Battery Voltage

The diagnostic display on the platform controls is used to indicate the battery voltage at all times when the machine is in normal operation.

Limp Mode: If the battery level falls to less than 17.8V DC, the single bar in the diagnostic display will be flashing and machine drive speed is limited to that of the raised drive speed. Refer to Section 2, *Specifications*.



the battery level is 22.6V DC or higher



the battery level is 21.6 to 22.5V DC



the battery level is 20.7 to 21.5V DC



the battery level is 19.7 to 20.6V DC



the battery level is 17.8 to 19.6V DC



the battery level is less than 17.8V DC

Platform Components

REV C

2-1 Platform

How to Remove the Platform

- 1 Raise the platform approximately 1 foot / 30 cm.
- 2 Place support blocks between the platform and the drive chassis. Lower the platform onto the blocks.

WARNING Crushing hazard. Keep hands clear when lowering the platform.

- 3 Turn the key switch to the off position and disconnect the battery pack from the machine.

WARNING Electrocutation/burn hazard. Contact with electrically charged circuits could result in death or serious injury. Remove all rings, watches and other jewelry.

- 5 Disconnect the platform controls from the control cable at the platform. Remove the platform controls from the platform and set the controls to the side.
- 6 Carefully cut the cable ties securing the control cable to the platform.

NOTICE Component damage hazard. The control cable can be damaged if cut while removing the cable ties.

- 7 Remove the fasteners securing the junction box bracket to the mast. Set the bracket and fasteners to the side.
- 3 Attach a lifting strap of suitable capacity from an overhead crane and center it around the platform railing. Support the platform. Do not apply any lifting pressure.
- 8 Remove the fasteners securing the platform mount to the mast and set the fasteners to the side. Remove the platform and mount from the machine.

WARNING Crushing hazard. The platform could become unbalanced and fall if not properly supported when removed from the machine.

2-2 Platform Extension

How to Remove the Platform Extension

- 1 Turn the key switch to the off position.
- 2 Disconnect the battery pack from the machine.

WARNING Electrocutation/burn hazard. Contact with electrically charged circuits could result in death or serious injury. Remove all rings, watches and other jewelry.

- 3 Disconnect the platform controls from the control cable at the platform, and remove the platform controls from the platform. Set the platform controls to the side.
- 4 Slide the extension deck forward until the holes at the front of the extension deck are aligned with the fasteners of the slide blocks, at the front of the main deck.

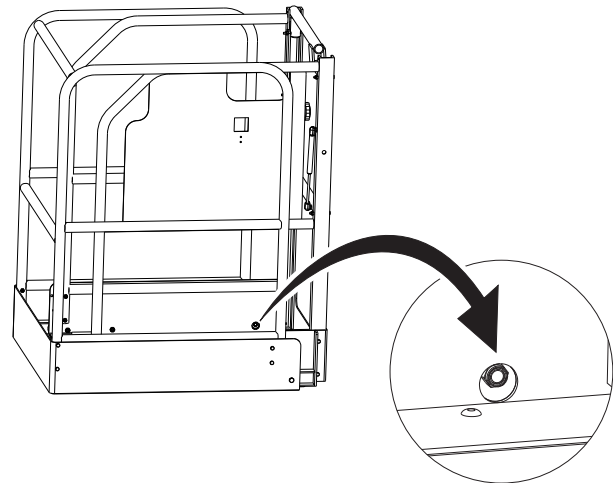

- 5 Remove the fasteners securing the white slide blocks to the main deck. Set the slide blocks and the fasteners to the side.
- 6 Activate the foot release latch and slide the extension platform out of the platform.

REV C

PLATFORM COMPONENTS

2-3 Work Tray

How to Remove the Work Tray (if equipped)

- 1 Turn the key switch to the off position.
- 2 Disconnect the battery pack from the machine.

⚠WARNING Electrocutation/burn hazard. Contact with electrically charged circuits could result in death or serious injury. Remove all rings, watches and other jewelry.

- 3 Disconnect the platform controls coli cord, from the control cable at the platform.
- 4 Remove the fasteners and spacer securing the platform controls to the platform controls mount. Remove the platform controls from the platform and set the controls to the side.
- 5 While supporting the work tray, remove the fasteners, bushings and spacers securing the work tray to the steer end, vertical platform rails. Set the fasteners, bushing and spacers to the side. Remove the work tray from the platform.

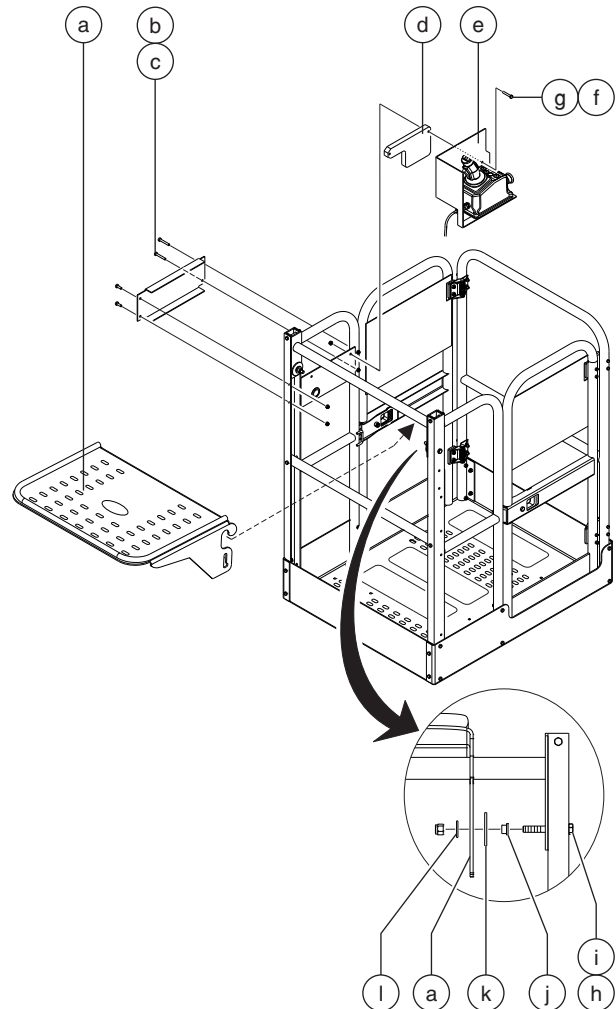

- a work tray
- b screw
- c nylock nut
- d platform controls spacer
- e platform controls assembly
- f screw
- g nylock not
- h screw
- i nylock nut
- j bushing
- k spacer
- l waasher

Mast Components

REV B

3-1 Mast

How to Remove the Mast Assembly

▲WARNING Bodily injury hazard. This procedure requires specific repair skills, lifting equipment and a suitable workshop. Attempting this procedure without these skills and tools could result in death or serious injury and significant component damage. Dealer service is strongly recommended.

Note: When removing a hose assembly or fitting, the O-ring on the fitting and/or hose end must be replaced and then torqued to specification during installation. Refer to Section Two, *Hydraulic Hose and Fitting Torque Specifications*.

Note: Perform this procedure on a firm, level surface, with the mast in the stowed position.

- 1 Remove the Platform. See 2-1, *How to Remove the Platform*.
- 2 Tag and disconnect the power to platform wire harness at the quick disconnect near the Electronic Control Module (ECM).
- 3 Tag and disconnect the ECM wire harness at the quick disconnect near the ECM.
- 4 Attach a lifting strap of suitable capacity from an overhead crane to the lifting eye at the top of the mast. Support the mast. Do not apply any lifting pressure.
- 5 Tag, disconnect and plug the lift cylinder hoses at the function manifold. Cap the fittings.

▲WARNING Bodily injury hazard. Spraying hydraulic oil can penetrate and burn skin. Loosen hydraulic connections very slowly to allow the oil pressure to dissipate gradually. Do not allow oil to squirt or spray.

- 6 Remove the fasteners securing the lower rear access cover to the chassis and remove the cover. Set the cover and the fasteners to the side.
- 7 Tag and disconnect the wire harness from the platform down valve coil at the base of the lift cylinder.
- 8 Remove the retaining nut securing the platform down coil to the platform down solenoid valve and remove the coil. Set the coil and retaining nut to the side.
- 9 Remove the platform down solenoid valve from the lift cylinder. Set the valve to the side and plug the cylinder port.

▲WARNING Bodily injury hazard. Spraying hydraulic oil can penetrate and burn skin. Loosen hydraulic connections very slowly to allow the oil pressure to dissipate gradually. Do not allow oil to squirt or spray.

- 10 Remove the mast retaining fasteners.
- 11 Carefully pull the hydraulic hoses free while removing the mast from the machine.

▲WARNING Crushing hazard. The mast assembly could become unbalanced and fall if not properly supported when removed from the machine.

NOTICE Component damage hazard. Cables and hoses can be damaged if they are kinked or pinched.

- 12 Place the mast assembly on a suitable structure capable of supporting it.

REV B

MAST COMPONENTS

How to Disassemble the Mast

⚠WARNING Bodily injury hazard. This procedure requires specific repair skills, lifting equipment and a suitable workshop. Attempting this procedure without these skills and tools could result in death or serious injury and significant component damage. Dealer service is strongly recommended.

- 1 Remove the mast. See 3-1, *How to Remove the Mast Assembly*.
- 2 Rotate the mast until the carriage is facing up.
- 3 Remove the socket head retaining fastener from the clevis block on the lift cylinder rod end at the top of the number 1 column.

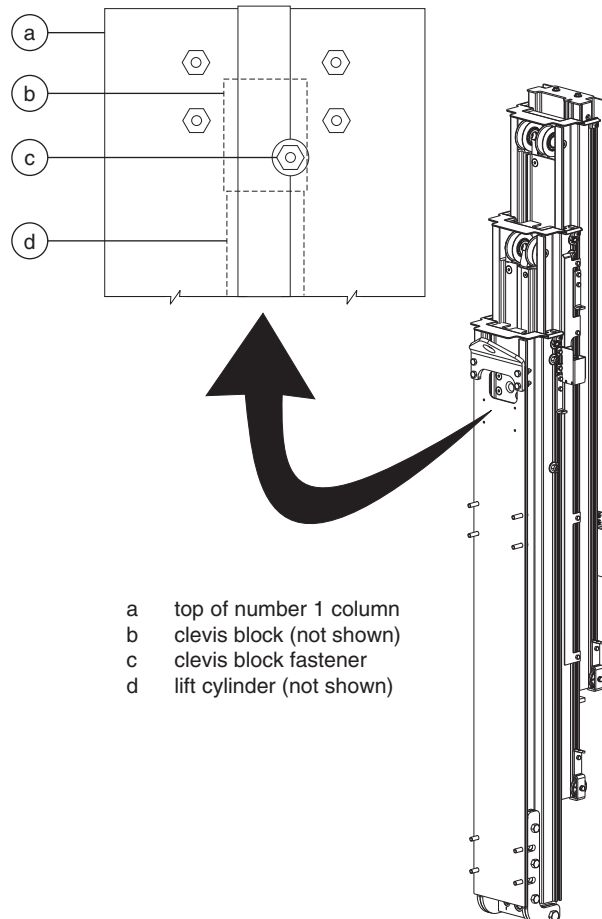

- a top of number 1 column
- b clevis block (not shown)
- c clevis block fastener
- d lift cylinder (not shown)

- 4 Remove the lift cylinder barrel end mounting fasteners.

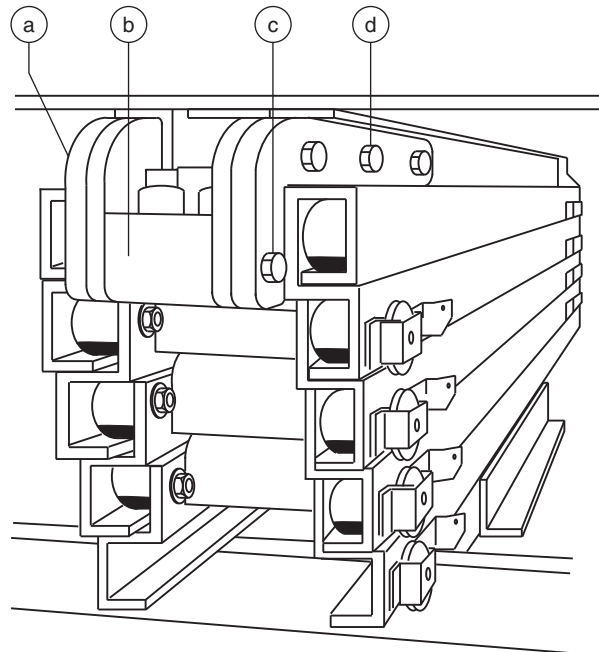

- a cylinder mounting plate
- b cylinder
- c cylinder mounting bolt
- d plate mounting fasteners

- 5 Loosen the lift cylinder mounting bracket fasteners.
- 6 Support the cylinder and carefully slide it out of the mast assembly.

⚠WARNING Crushing hazard. The lift cylinder could become unbalanced and fall if not properly supported when removed from the machine.

MAST COMPONENTS

REV B

- 7 Remove the cover from the top of each column.
- 8 Remove the adjustment nuts from all of the sequencing cables.
- 9 Slide the carriage toward the top of the mast assembly enough to remove the tension on the lifting chains.
- 10 Slide the column below the carriage toward the top of the mast assembly approximately 6 inches / 15 cm to access the idler wheel mounting fasteners.
- 11 Hold the idler wheel axle from turning by placing a screwdriver through the hole in the axle. Remove the axle mounting fasteners and remove the idler wheel assembly.
- 12 Remove the adjustment nuts from the chain tension rocker on the carriage.
- 13 Slide the carriage out the bottom of the mast assembly.
- 14 Lay the chains out on the floor at the top of the mast.
- 15 Remove the adjustment nuts from the chain tension rocker on the column.
- 16 Remove the column by sliding the column out the bottom of the mast.
- 17 Push the next column toward the top of the mast to access the idler wheel assembly mounting fasteners.
- 18 Hold the idler wheel axle from turning by placing a screwdriver through the hole in the axle. Remove the axle mounting fasteners, and remove the idler wheel assembly.
- 19 Remove the adjustment nuts from the chain tension rocker on the column.
- 20 Slide the column out the bottom of the mast.
- 21 Repeat steps 17 through 20 for each remaining column.

Note: Label the location and orientation of each idler wheel assembly.

Note: If the chains are to be removed, mark the location and label each chain before removal.

Note: Do not allow the chains to become twisted or dirty.

REV B

MAST COMPONENTS

How to Assemble the Mast

⚠WARNING Bodily injury hazard. This procedure requires specific repair skills, lifting equipment and a suitable workshop. Attempting this procedure without these skills and tools could result in death or serious injury and significant component damage. Dealer service is strongly recommended.

- 1 Thoroughly clean all columns.
- 2 Secure the number 1 column to the work table and lay the chains out on the floor.

Note: Do not allow the chains to become twisted or dirty.

- 3 Apply a generous amount of Boe-lube wax to the inside and outside channels of each column.
- 4 Slide the number 2 column into the number 1 column.
- 5 Lay the number 2 column chains on the floor.

Note: Do not allow the chains to become twisted or dirty.

- 6 Lay the number 1 column chains inside the number 2 column.
- 7 Slide the number 3 column into the number 2 column.
- 8 When the number 3 column is almost all the way in, guide the number 1 column chains into the chain tension rocker on the number 3 column.
- 9 Install the adjustment nuts on the number 1 column chains. Tighten the adjustment nuts until the lifting chains have equal tension and the chain tension rocker is centered in the inspection hole in the column.

- 10 Lay the number 3 column chains on the floor.

Note: Do not allow the chains to become twisted or dirty.

- 11 Lay the number 2 column chains inside the number 3 column.
- 12 Follow steps 4 through 11 for each remaining column and the carriage.
- 13 After all the columns are assembled, the idler wheel assemblies can be installed.
- 14 Remove the tension from the lifting chains on the number 2 column by pushing the number 3 column towards the top of the mast.
- 15 Install the idler wheel assembly in the top of the number 2 column. Tighten the mounting fasteners.

Note: Confirm that all idler wheels rotate smoothly with no excessive side movement, or rub on the inside of the column. Replace worn shims if necessary.

- 16 Repeat steps 14 and 15 for each remaining idler wheel assembly.
- 17 Confirm that all of the idler wheel axle mounting fasteners are flush with the column.

NOTICE Component damage hazard. The roller wheels may be damaged if the idler wheel axle mounting fasteners are not flush with the column.

- 18 Install the mast assembly on the drive chassis. Adjust the lifting chains. See 3-3, *How to Adjust the Lifting Chains*.

MAST COMPONENTS

REV B

3-2 Glide Pads

Glide pads, used on the GR-12, GR-15, QS-12R, QS-15R, QS-12W and QS-15W, and wear pads used on the GR-20, QS-20R and QS-20W, are used to provide a uniform fit between the columns as the mast extends and retracts. Over time, it may be necessary to adjust the glide pads to ensure good machine performance.

Wear pads are not adjustable and do not require servicing.

How to Adjust the Glide Pads

- 1 Locate the upper and lower glide pad adjustment bolts below each upper roller bolt, on both sides of each column.
- 2 Hold the glide pad adjustment bolt and loosen the lock nut on all glide pads.
- 3 Turn the glide pad adjustment bolt clockwise until the glide pad makes contact with the column. Adjust the glide pads on both sides of all columns. Be sure the sides of the columns are even to within $\frac{1}{8}$ inch / 3 mm of each other.
- 4 On the number 1 column, secure the upper and lower glide pad bolts on both sides of the mast. Hold the glide pad adjustment bolt and torque the lock nut to 12 in-lbs / 1.35 Nm. Be sure the glide pad bolt does not turn.
- 5 Repeat step 5 for the upper and lower glide pads on both sides of the each column of the mast, Start with the number 2 column and work toward the carriage.

3-3 Lifting Chains

How to Adjust the Lifting Chains

- 1 Mark the column to be adjusted.
- 2 Raise the platform approximately 6 feet / 2 m.
- 3 Place a lifting strap of suitable capacity from an overhead crane under the platform. Support the platform. Do not apply any lifting pressure.

NOTICE Component damage hazard. The platform railings and platform extension deck (if equipped) can be damaged if they are used to lift the platform. Do not attach the lifting strap to the platform railings or the platform extension deck.

- 4 Turn the adjustment lock nuts evenly on both sides of the chain tension rocker clockwise to raise the column or counterclockwise to lower the column.

Note: The chain tensioner rocker is located near the bottom of each column.

- 5 Fully lower the platform and confirm the alignment of the columns. Repeat steps 2 through 5 if necessary.
- 6 Confirm that the chain tensioner bracket is centered in the inspection hole.

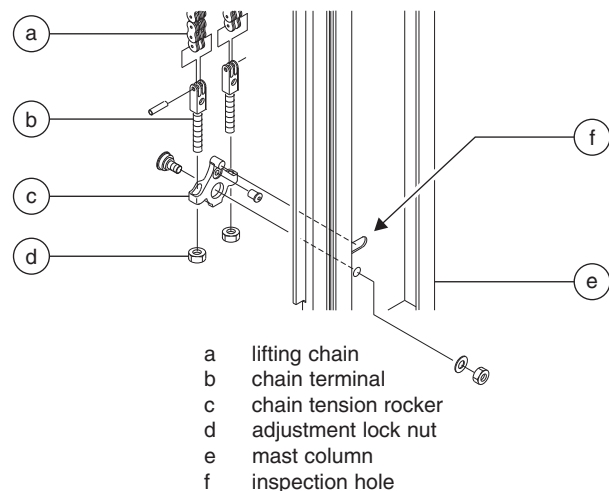

REV B

MAST COMPONENTS

How to Inspect the Lifting Chains



Inspection	Procedure	Inspection Failure	Inspection Remedy
Wear	Count out 16 chain links and measure pin to pin centerline dimension with a steel measuring tape. Note: Measure a section of chain that moves over the idler wheels.	When the length of the 16 links (pin to pin) measure more than 8.25 inches / 21 cm for 1/2 inch / 12.7mm chain or 10.31 inches / 26.1 cm for 5/8 inch / 15.9 mm chain.	Replace both chains on that column. Replace entire chain. Do not repair just the affected portion of the chain.
Rust and Corrosion	Visually inspect the chains for rust and corrosion.	Evidence of rust or corrosion.	Remove chain and inspect for cracked plates (see inspection of cracked plates). If no cracks are found, lubricate chain with motor oil (SAE 40) and install chain.
	Visually inspect the chains for lubrication.	When external surfaces are not protected with a layer of oil.	Lubricate chain with motor oil (SAE 40W).
Tight Joints	Inspect chain link joints for easy movement.	Joints that do not flex freely or are binding.	If rust and corrosion is found, refer to Failure Remedy for rust and corrosion. If link plates or pins are bent or deformed, replace entire chain. Replace both chains on that column. Do not repair just the affected portion of the chain.



Continued to the next page

MAST COMPONENTS

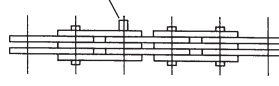
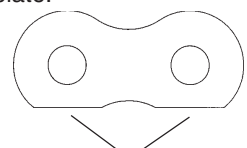
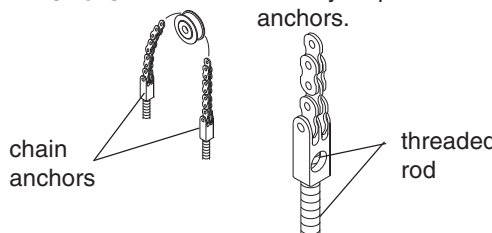
REV B

Inspection	Procedure	Inspection Failure	Inspection Remedy
Raised or Turned Pins	<p>Visually inspect for raised pins.</p> <p>Visually inspect for turned pins by insuring all the flats on the "V" heads are aligned.</p>	<p>Raised pins.</p>  <p>Misalignment of flats on all "V" heads.</p>	<p>Replace both chains on that column section. Do not repair just the affected portion of the chain.</p> <p>Replace both chains on that column section. Do not repair just the affected portion of the chain.</p>
Chain Side	<p>Visually inspect for wear patterns on heads of link pins and outside link plates where they contact the idler wheel.</p>	<p>Wear on pin heads or noticeable wear in the profile of the outside link plate.</p>  <p>link plate wear</p>	<p>Replace both chains on that column section. Do not repair just the affected portion of the chain.</p> <p>Check alignment of chain anchors and idler wheels.</p> <p>Replace chain anchor.</p>
<p>Chain Anchors</p>  <p>chain anchors</p> <p>threaded rod</p>	<p>Visually inspect chain anchors.</p>	<p>Broken chain anchor fingers.</p> <p>Bent or damaged anchor.</p> <p>Twisted or misaligned chain anchor.</p> <p>Threaded rod not visible in inspection hole.</p>	<p>Replace chain anchor.</p> <p>Replace chain anchor and threaded rod.</p> <p>Re-align chain anchor to ensure even loading of chain.</p> <p>Replace idler wheel and check chain alignment.</p>
<p>Idler Wheels</p>  <p>idler wheel</p>	<p>Visually inspect chain idler wheels.</p>	<p>Idler wheels have badly worn flanges.</p> <p>Idler wheels have grooves worn into chain contact surface.</p>	<p>Replace idler wheel.</p> <p>Replace both chains on that column section.</p>
Cracked Link Plates	<p>Visually inspect chain link plates for cracks.</p>	<p>Cracks in any chain link plate.</p>	<p>Replace entire chain. Do not repair just the affected portion of the chain.</p>

REV B

MAST COMPONENTS

3-4 Lift Cylinder

The lift cylinder is equipped with a normally closed solenoid valve to prevent movement in the event of a hydraulic line failure.

How to Remove the Lift Cylinder

⚠WARNING Bodily injury hazard. This procedure requires specific repair skills, lifting equipment and a suitable workshop. Attempting this procedure without these skills and tools could result in death or serious injury and significant component damage. Dealer service is strongly recommended.

Note: When removing a hose assembly or fitting, the O-ring on the fitting and/or hose end must be replaced and then torqued to specification during installation. Refer to Section Two, *Hydraulic Hose and Fitting Torque Specifications*.

- 1 Remove the mast. See 3-1, *How to Remove the Mast Assembly*.
- 2 Rotate the mast until the carriage is facing down.
- 3 Remove the socket head retaining fastener from the clevis block on the lift cylinder rod end at the top of the number 1 column.
- 4 Remove the lift cylinder barrel end mounting fasteners.
- 5 Loosen the lift cylinder mounting bracket fasteners.
- 6 Support the cylinder and carefully slide it out of the mast assembly.

⚠WARNING Crushing hazard. The lift cylinder could become unbalanced and fall if not properly supported when removed from the mast.

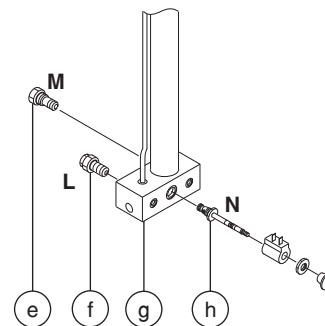
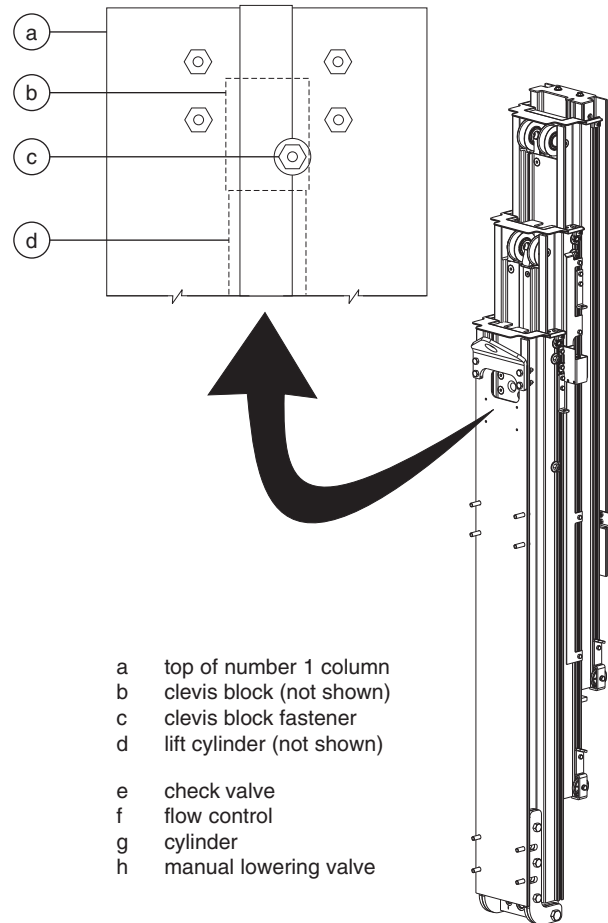

Ground Controls

REV B

4-1 Level Sensor

The Electronic Control Module (ECM) is programmed to deactivate the lift and drive functions and activate an alarm when a signal is received from the level sensor.

The tilt alarm sounds when the incline of the chassis exceeds 1.5° to the side, or 3° to the front or rear.

How to Install and Calibrate the Level Sensor

⚠ DANGER Tip-over hazard. Failure to install or calibrate the level sensor as instructed will compromise machine stability and cause the machine to tip over, resulting in death or serious injury. Do not install or calibrate the level sensor other than specified in this procedure.

Note: Perform this procedure with the machine on a firm, level surface, free of obstructions.

Note: Perform this procedure with the platform in the stowed position.

If you are not installing a new level sensor, proceed to step 6.

- 1 Tag and disconnect the level sensor wire harness from the chassis wire harness.
- 2 Remove the level sensor adjusting fasteners. Remove the level sensor from the machine.

- 3 Place the new level sensor onto the level sensor base with the "X" on the level sensor closest to the mast of the machine and the "Y" on the level sensor closest to the steer end of the machine.

⚠ DANGER Tip-over hazard. The level sensor must be installed with the "X" on the level sensor closest to the mast of the machine and the "Y" on the level sensor closest to the steer end of the machine. Failure to install the tilt level sensor as instructed could result in the machine tipping over, causing death or serious injury.

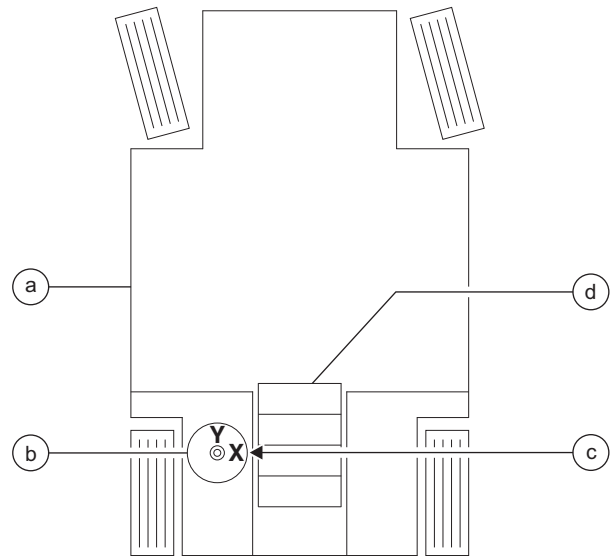

- a chassis
- b level sensor
- c 'X' indicator
- d mast

REV B

GROUND CONTROLS

- 4 Install the level sensor adjusting fasteners through the level sensor and springs, and into the mount. Tighten the fasteners and measure the distance between the level sensor and the level sensor mount.
- ⊙ Result: The measurement should be approximately $\frac{3}{8}$ inch / 10 mm.
- 5 Connect the chassis wire harness to the level sensor wire harness.
- 6 Tighten the level sensor adjusting fasteners until the bubble in the top of the level sensor is centered in the calibration circles.

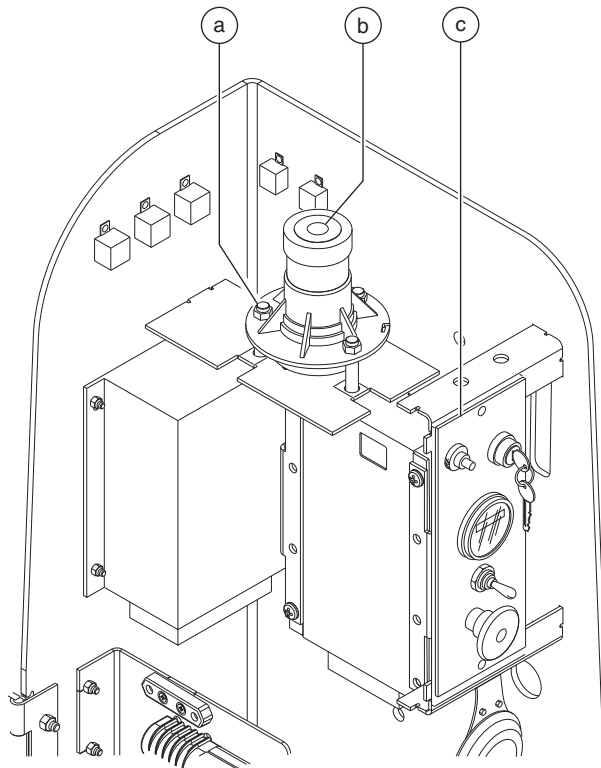

- a adjusting fastener
 b calibration circles
 c ground controls

- 7 Turn the key switch to ground control and pull out the red Emergency Stop button to the on position at both the ground and platform controls.
- ⊙ Result: The tilt sensor alarm should not sound.
- 8 Center a lifting jack under the drive chassis at the ground controls side of the machine.
- 9 Raise the machine approximately 2 inches / 5 cm.
- 10 **GR-12, GR-15, QS-12R, QS-15R, QS-12W and QS-15W:** Place a 0.65 x 6 x 6 inch / 1.65 x 15 x 15 cm thick steel block under both wheels at the ground controls side of the machine.
GR-20, QS-20R and QS-20W: Place a 0.7 x 6 x 6 inch / 1.78 x 15 x 15 cm thick steel block under both wheels at the ground controls side of the machine.
- 11 Lower the machine onto the blocks.
- 12 Raise the platform approximately 1 foot / 30 cm.
- ⊙ Result: The level sensor alarm should not sound.
- ⊗ Result: The level sensor alarm does sound. Adjust the level sensor retaining fasteners just until the level sensor alarm does not sound.
- 13 Lower the platform to the stowed position.
- 14 Raise the machine slightly.
- 15 Remove the blocks from under both wheels.
- 16 Lower the machine and remove the jack.
- 17 Center a lifting jack under the drive chassis at the tank side of the machine.

GROUND CONTROLS

REV B

- 18 Raise the machine approximately 2 inches / 5 cm.
- 19 **GR-12, GR-15, QS-12R, QS-15R, QS-12W and QS-15W:** Place a 0.79 x 6 x 6 inch / 2 x 15 x 15 cm thick steel block under both wheels at the tank side of the machine.
- GR-20, QS-20R and QS-20W:** Place a 0.85 x 6 x 6 inch / 2.16 x 15 x 15 cm thick steel block under both wheels at the tank side of the machine.
- 20 Lower the machine onto the blocks.
- 21 Raise the platform approximately 1 foot / 30 cm.
- ⦿ Result: The platform should stop and an alarm should sound.
 - ✗ Result: The platform does not stop or the level sensor alarm does not sound. Adjust the level sensor until the alarm just begins to sound OR the down limit switch may need to be adjusted.
- 22 Lower the platform to the stowed position.
- 23 Raise the machine slightly.
- 24 Remove the blocks from under both wheels.
- 25 Lower the machine and remove the jack.
- 26 Center a lifting jack under the drive chassis at the steer end of the machine.
- 27 Raise the machine approximately 2 inches / 5 cm.
- 28 Place a 2.18 x 6 x 6 inch / 5.54 x 15 x 15 cm thick steel block under both wheels at the steer end of the machine.
- 29 Lower the machine onto the blocks.
- 30 Raise the platform approximately 1 foot / 30 cm.
- ⦿ Result: The level sensor alarm should not sound.
 - ✗ Result: The level sensor alarm does sound. The level sensor is faulty and must be replaced. Repeat this procedure beginning with step 1.
- 31 Raise the machine slightly.
- 32 Remove the blocks from under both wheels.
- 33 Lower the machine and remove the jack.
- 34 Center a lifting jack under the drive chassis at the non-steer end of the machine.
- 35 Raise the machine approximately 2 inches / 5 cm.
- 36 Place a 2.4 x 6 x 6 inch / 6.1 x 15 x 15 cm thick steel block under both wheels at the non-steer end of the machine.
- 37 Raise the platform approximately 1 foot / 30 cm.
- ⦿ Result: The platform should stop and an alarm should sound.
 - ✗ Result: The platform does not stop or the level sensor alarm does not sound. The level sensor is faulty and must be replaced. Repeat this procedure beginning with step 1.
- 38 Lower the platform to the stowed position.
- 39 Raise the machine slightly.
- 40 Remove the blocks from under both wheels.
- 41 Lower the machine and remove the jack.

Hydraulic Pump

REV A

5-1 Function Pump

The hydraulic pump is attached to the motor which makes up the hydraulic power unit.

How to Test the Hydraulic Pump

Note: When removing a hose assembly or fitting, the fitting and/or hose end must be torqued to specification during installation. Refer to Section 2, *Hydraulic Hose and Fitting Torque Specifications*.

- 1 Tag, disconnect and plug the high pressure hydraulic hose from the hydraulic pump.

⚠ WARNING Bodily injury hazard. Spraying hydraulic oil can penetrate and burn skin. Loosen hydraulic connections very slowly to allow the oil pressure to dissipate gradually. Do not allow oil to squirt or spray.

- 2 Connect a 0 to 5000 psi / 0 to 350 bar pressure gauge to the high pressure port on the pump.
- 3 Turn the key switch to ground control and pull out the red Emergency Stop button to the on position at both the ground and platform controls.

- 4 Activate the platform up function from the ground controls.
 - ⊙ Result: If the pressure gauge reads 3200 psi / 221 bar, immediately stop. The pump is good.
 - ⊙ Result: If pressure fails to reach 3200 psi / 221 bar, the pump is bad and will need to be serviced or replaced.

NOTICE Component damage hazard. There is no relief valve in the hydraulic pump and the pump can be damaged if the pressure is allowed to exceed 3200 psi / 221 bar. When testing the pump, activate the pump in one second intervals until 3200 psi / 221 bar is confirmed. Do not over-pressurize the pump.

- 5 Remove the pressure gauge and reconnect the hydraulic hose. Torque to specification.

⚠ WARNING Bodily injury hazard. Spraying hydraulic oil can penetrate and burn skin. Loosen hydraulic connections very slowly to allow the oil pressure to dissipate gradually. Do not allow oil to squirt or spray.

HYDRAULIC PUMP

REV A

How to Remove the Hydraulic Pump

Note: When removing a hose assembly or fitting, the O-ring on the fitting and/or hose end must be replaced and then torqued to specification during installation. Refer to Section Two, *Hydraulic Hose and Fitting Torque Specifications*.

- 1 Tag, disconnect and plug the hydraulic supply hard line at the pump. Cap the fitting on the pump.
- 2 Tag, disconnect and plug the high pressure hose at the pump. Cap the fitting on the pump.

AWARNING Bodily injury hazard. Spraying hydraulic oil can penetrate and burn skin. Loosen hydraulic connections very slowly to allow the oil pressure to dissipate gradually. Do not allow oil to squirt or spray.

- 3 Remove the pump mounting bolts. Carefully remove the pump.

▲ DANGER Tip-over hazard. After replacing the hydraulic pump, it is critical to return the function speed settings to original factory specifications. Failure to restore the machine to original factory specifications could cause the machine to tip over, resulting in death or serious injury.

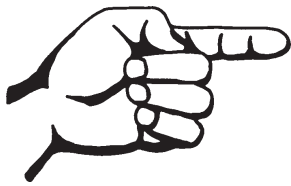

This page intentionally left blank.

Function Manifold

REV B

6-1

Function Manifold Components

The function manifold is mounted next to the hydraulic power unit.

Index No.	Description	Schematic Item	Function	Torque
—	Coil nut (items E, F and H)			5 ft-lbs / 7 Nm
1	Diagnostic nipple	A	Testing	
2	Check disc	B	Steer circuit	18 ft-lbs / 24 Nm
3	Relief valve, 1800 to 3500 psi / 124 to 241 bar	C	Lift relief	20 ft-lbs / 27 Nm
4	Check valve, 10 psi / 0.7 bar	D	Drive circuit	20 ft-lbs / 27 Nm
5	Solenoid valve, 3 position 4 way	E	Drive forward/reverse	25 ft-lbs / 34 Nm
6	Solenoid valve, 3 position 4 way	F	Steer left/right	25 ft-lbs / 34 Nm
7	Flow regulator and relief valve, 0.75 gpm / 2.8 L/min, 1500 psi / 103 bar	G	Steer circuit	26 ft-lbs / 35 Nm
8	Solenoid valve, 2 position 4 way	H	Platform up	25 ft-lbs / 34 Nm
9	Relief valve, 3500 psi / 241 bar maximum	I	System relief	20 ft-lbs / 27 Nm

REV B

FUNCTION MANIFOLD

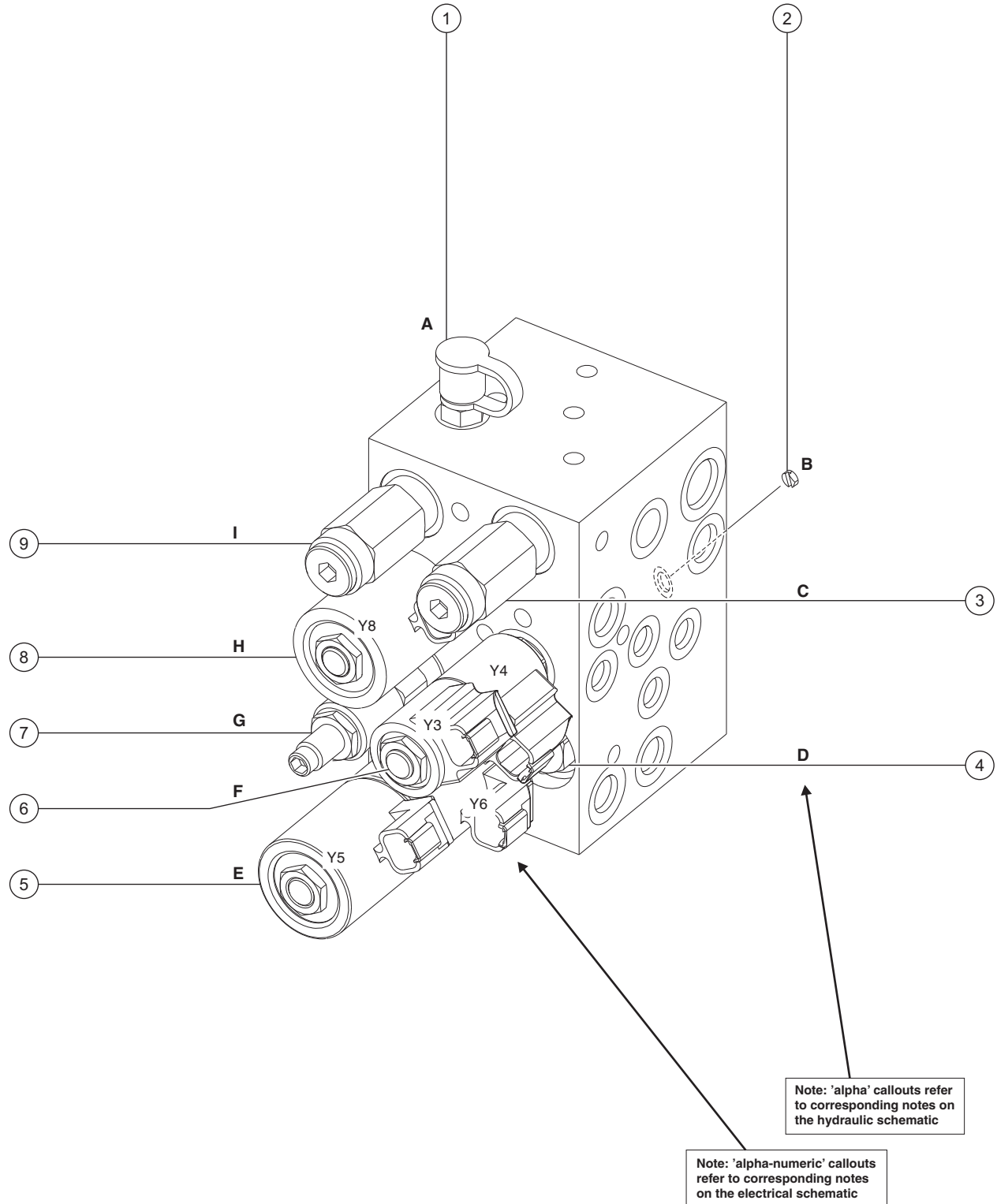

FUNCTION MANIFOLD

REV B

6-2 Valve Adjustments - Function Manifold

How to Adjust the System Relief Valve

Note: Be sure that the hydraulic oil level is at the FULL mark on the hydraulic tank.

- 1 Locate the system relief valve on the function manifold (item I).

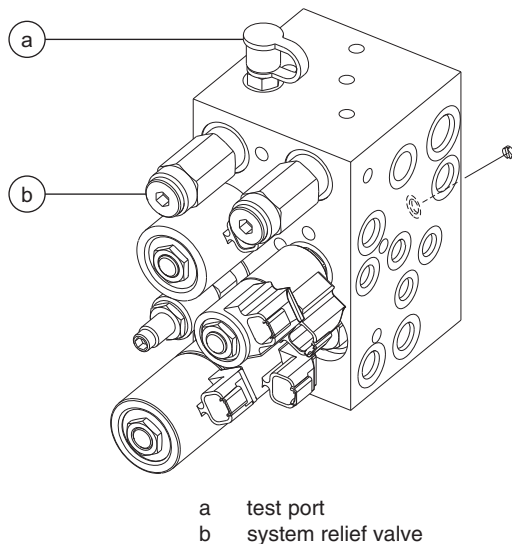

- 2 Connect a 0 to 5000 psi / 0 to 350 bar pressure gauge to the test port on the function manifold (schematic item A).

- 3 Chock both sides of the wheels at the steer end of the machine.
- 4 Remove the platform controls from the platform.

Note: Perform this test from the ground with the platform controls. Do not stand in the platform.

- 5 Turn the key switch to platform control and pull out the red Emergency Stop button to the on position at both the ground and platform controls.
- 6 Press and hold the function enable switch.
- 7 Move and hold the joystick fully in either direction while observing the pressure reading on the pressure gauge. Note the pressure. Refer to Section 2, *Specifications*.
- 8 Turn the machine off. Hold the system relief valve with a wrench and remove the cap (schematic item I).
- 9 Adjust the internal hex socket. Turn it clockwise to increase the pressure or counterclockwise to decrease the pressure.

⚠ DANGER Tip-over hazard. Failure to adjust the relief valves to specification could result in the machine tipping over, causing death or serious injury. Do not adjust the relief valve pressures higher than specifications.

- 10 Install the relief valve cap.
- 11 Repeat steps 5 through 7 to confirm the relief valve pressure.

REV B

FUNCTION MANIFOLD

How to Adjust the Platform Lift Relief Valve

Note: Be sure that the hydraulic oil level is at the FULL mark on the hydraulic tank.

- 1 Locate the system relief valve on the function manifold (item I).

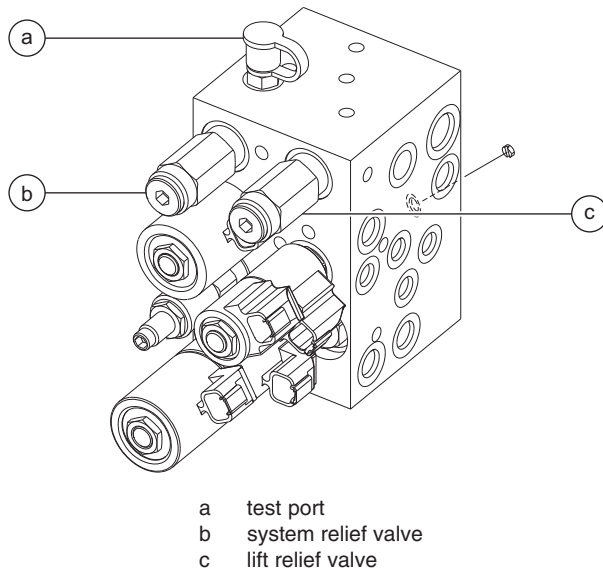

- 2 Connect a 0 to 5000 psi / 0 to 350 bar pressure gauge to the test port on the function manifold (schematic item A).
- 3 Chock both sides of the wheels at the steer end of the machine.
- 4 Remove the platform controls from the platform.

Note: Perform this test from the ground with the platform controls. Do not stand in the platform.

- 5 Turn the key switch to platform control and pull out the red Emergency Stop button to the on position at both the ground and platform controls.
- 6 Press and hold the function enable switch.
- 7 Move and hold the joystick fully in either direction while observing the pressure reading on the pressure gauge. Note the pressure. Refer to Section 2, *Specifications*.
- 8 Turn the machine off. Hold the system relief valve with a wrench and remove the cap (hydraulic schematic item I).
- 9 Adjust the internal hex socket. Turn it clockwise to increase the pressure or counterclockwise to decrease the pressure.

⚠ DANGER Tip-over hazard. Failure to adjust the relief valves to specification could result in the machine tipping over, causing death or serious injury. Do not adjust the relief valve pressures higher than specifications.

- 10 Install the relief valve cap.
- 11 Repeat steps 4 through 7 to confirm the relief valve pressure.
- 12 Place maximum rated load into the platform. Secure the load to the platform. Refer to Section 2, *Specifications*.
- 13 Turn the key switch to ground control and pull out the red Emergency Stop button to the on position at both the ground and platform controls.

FUNCTION MANIFOLD

REV B

- 14 Hold the lift relief valve with a wrench and remove the cap (schematic item C).
- 15 While activating the platform up function, adjust the internal hex socket clockwise, just until the platform fully raises.
- 16 Fully lower the platform.
- 17 Add an additional 50 pounds / 22.7 kg to the platform. Secure the additional weight.
- 18 Attempt to raise the platform.
- ⊙ Result: The power unit should **not** be able to lift the platform.
- ⊗ Result: If the power unit lifts the platform, adjust the internal hex socket counterclockwise until the platform will not raise.
- 19 Install the relief valve cap.
- 20 Remove the weight from the platform.
- 21 Bleed the hydraulic system by raising the platform to full height. If the pump cavitates or the platform fails to reach full height, add hydraulic oil until the pump is functioning correctly. Do not overfill the hydraulic tank.

NOTICE Component damage hazard. Do not continue to operate the machine if the hydraulic pump is cavitating.

How to Adjust the Steer Relief Valve

Note: Be sure that the hydraulic oil level is at the FULL mark on the hydraulic tank.

- 1 Locate the steer relief valve on the function manifold (schematic item G).

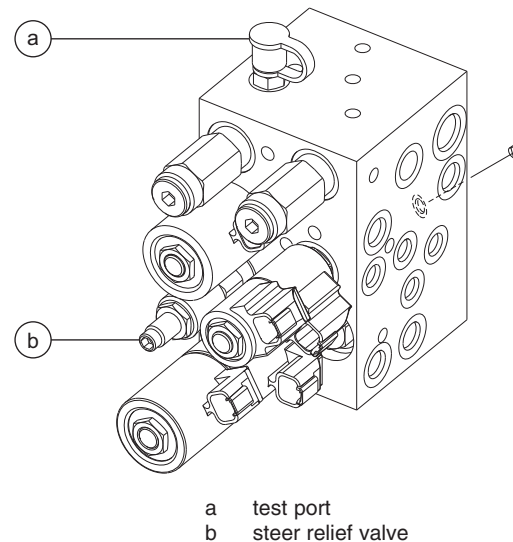

- 2 Connect a 0 to 5000 psi / 0 to 350 bar pressure gauge to the test port (schematic item A) on the function manifold.
- 3 Remove the platform controls from the platform.

Note: Perform this test from the ground with the platform controls. Do not stand in the platform.

REV B

FUNCTION MANIFOLD

- 4 Turn the key switch to platform control and pull out the red Emergency Stop button to the on position at both the ground and platform controls.
- 5 Activate the function enable switch and press and hold the steer thumb rocker switch to the right. Allow the wheels to completely turn to the right. Continue holding the switch while observing the pressure reading on the pressure gauge. Note the pressure. Refer to Section 2, *Specifications*.
- 6 Press and hold the steer thumb rocker switch to the left. Allow the wheels to completely turn to the left. Continue holding the switch while observing the pressure reading on the pressure gauge.
- 7 Turn the machine off. Hold the steer relief valve with a wrench and remove the cap (schematic item G).
- 8 Adjust the internal hex socket. Turn it clockwise to increase the pressure or counterclockwise to decrease the pressure.

NOTICE Component damage hazard. Do not adjust the relief valve pressures higher than specifications.

- 9 Install the relief valve cap.
- 10 Repeat steps 5 through 6 to confirm the relief valve pressure.

FUNCTION MANIFOLD

REV B

6-3 Valve Coils

How to Test a Coil

A properly functioning coil provides an electromagnetic force which operates the solenoid valve. Critical to normal operation is continuity within the coil. Zero resistance or infinite resistance indicates the coil has failed.

Since coil resistance is sensitive to temperature, resistance values outside specification can produce erratic operation. When coil resistance decreases below specification, amperage increases. As resistance rises above specification, voltage increases.

While valves may operate when coil resistance is outside specification, maintaining coils within specification will help ensure proper valve function over a wide range of operating temperatures.

⚠ WARNING Electrocuting/burn hazard. Contact with electrically charged circuits could result in death or serious injury. Remove all rings, watches and other jewelry.

Note: If the machine has been in operation, allow the coil to cool at least 3 hours before performing this test.

- 1 Tag and disconnect the wiring from the coil to be tested.
- 2 Test the coil resistance using a multimeter set to resistance (Ω). Refer to the Valve Coil Resistance Specification table.

✖ Result: If the resistance is not within the adjusted specification, plus or minus 10%, replace the coil.

Valve Coil Resistance Specification

Note: The following coil resistance specifications are at an ambient temperature of 68°F / 20°C. As valve coil resistance is sensitive to changes in air temperature, the coil resistance will typically increase or decrease by 4% for each 18°F / -7.7°C that your air temperature increases or decreases from 68°F / 20°C.

Valve Coil Resistance Specifications

Description	Specification
Solenoid valve, 3 position 4 way 20V DC with diode (schematic items E)	27.2 Ω
Solenoid valve, 3 position 4 way 20V DC with diode (schematic item F)	19 Ω
Solenoid valve, 2 position 4 way 20V DC with diode (schematic item H)	25 Ω
Solenoid valve, 2 position 2 way N.C. with manual override 12V DC with diode (schematic item N)	6.25 Ω

REV B

FUNCTION MANIFOLD

How to Test a Coil Diode

Genie incorporates spike suppressing diodes in all of its coils. Properly functioning coil diodes protect the electrical circuit by suppressing voltage spikes. Voltage spikes naturally occur within a function circuit following the interruption of electrical current to a coil. Faulty diodes can fail to protect the electrical system, resulting in a tripped circuit breaker or component damage.

⚠ WARNING Electrocutation/burn hazard. Contact with electrically charged circuits could result in death or serious injury. Remove all rings, watches and other jewelry.

- 1 Test the coil for resistance. See 6-3, *How to Test a Coil*.
- 2 Connect a 10Ω resistor to the negative terminal of a known good 9V DC battery. Connect the other end of the resistor to a terminal on the coil.

Note: The battery should read 9V DC or more when measured across the terminals.

Resistor, 10Ω

Genie part number	27287
-------------------	-------

- 3 Set a multimeter to read DC amperage.

Note: The multimeter, when set to read DC amperage, should be capable of reading up to 800 mA.

- 4 Connect the negative lead to the other terminal on the coil.

Note: If testing a single-terminal coil, connect the negative lead to the internal metallic ring at either end of the coil.

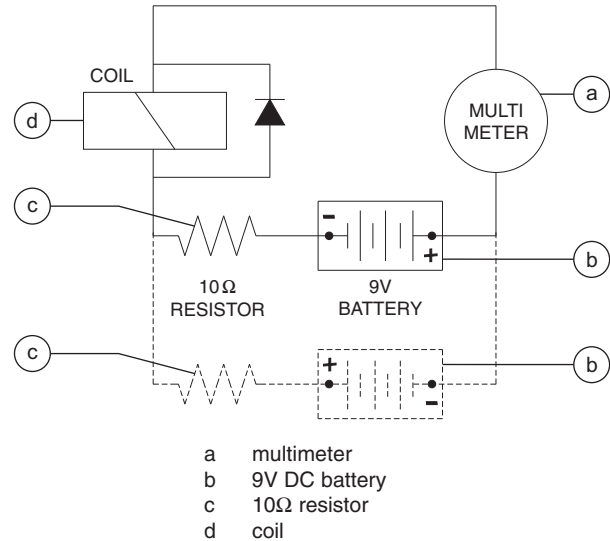

Note: Dotted lines in illustration indicate a reversed connection as specified in step 6

- 5 Momentarily connect the positive lead from the multimeter to the positive terminal on the 9V battery. Note and record the current reading.
 - 6 At the battery or coil terminals, reverse the connections. Note and record the current reading.
- ⊙ Result: Both current readings are greater than 0 mA and are different by a minimum of 20%. The coil is good.
 - ✗ Result: If one or both of the current readings are 0 mA, or if the two current readings do not differ by a minimum of 20%, the coil and/or its internal diode are faulty and the coil should be replaced.

Hydraulic Tank

REV A

7-1 Hydraulic Tank

The primary functions of the hydraulic tank are to cool and deaerate the hydraulic fluid during operation. It utilizes internal suction strainers for the pump supply lines and has an external return line filter.

How to Remove the Hydraulic Tank

NOTICE Component damage hazard. The work area and surfaces where this procedure will be performed must be clean and free of debris that could get into the hydraulic system.

Note: When removing a hose assembly or fitting, the fitting and/or hose end must be torqued to specification during installation. Refer to Section 2, *Hydraulic Hose and Fitting Torque Specifications*.

Note: Perform this procedure with the platform in the stowed position.

- 1 Tag, disconnect and plug the hydraulic supply hard line at the pump. Cap the fitting on the pump. Remove the hard line from the tank.

- 2 Tag, disconnect and plug the return hard line at the hydraulic filter. Cap the fitting on the filter.

WARNING Bodily injury hazard. Spraying hydraulic oil can penetrate and burn skin. Loosen hydraulic connections very slowly to allow the oil pressure to dissipate gradually. Do not allow oil to squirt or spray.

- 3 Remove the hydraulic tank retaining fasteners and remove the hydraulic tank from the machine.

Torque specifications

Hydraulic tank retaining fasteners, dry	35 in-lbs 4 Nm
Hydraulic tank retaining fasteners, lubricated	26 in-lbs 2.9 Nm

Steer Axle Components

REV A

8-1 Yoke and Drive Motor

How to Remove the Yoke and Drive Motor Assembly

Note: When removing a hose assembly or fitting, the fitting and/or hose end must be torqued to specification during installation. Refer to Section 2, *Hydraulic Hose and Fitting Torque Specifications*.

- 1 Block the wheels at the non-steer end of the machine.
- 2 Remove the cotter pin from the wheel castle nut at the steer end of the machine.

Note: Always replace the cotter pin with a new one when removing the castle nut.

- 3 Loosen the wheel castle nut. Do not remove it.
- 4 Center a lifting jack under the drive chassis at the steer end of the machine.
- 5 Raise the machine approximately 6 inches / 15 cm. Place blocks under the chassis for support.

▲WARNING Crushing hazard. The chassis could fall if not properly supported.

- 6 Remove the wheel castle nut. Remove the wheel.

- 7 Tag, disconnect and plug the hydraulic hoses on the drive motor. Cap the fittings on the drive motor.

▲WARNING Bodily injury hazard. Spraying hydraulic oil can penetrate and burn skin. Loosen hydraulic connections very slowly to allow the oil pressure to dissipate gradually. Do not allow oil to squirt or spray.

NOTICE Component damage hazard. Hoses can be damaged if they are kinked or pinched.

- 8 Support and secure the yoke assembly to an appropriate lifting device.
- 9 Remove the retaining fastener from the steer link at the yoke assembly.

Note: Observe and note the quantity and location of the spacers, when disconnecting the steer link from the yoke assembly.

- 10 Remove the retaining fastener from the rear of the yoke pivot shaft.

Note: The pivot shaft retaining fastener is located below the main deck.

- 11 Lower the yoke assembly out of the chassis.

▲CAUTION Bodily injury hazard. The yoke/motor assembly may fall if not properly supported when removed from the machine.

STEER AXLE COMPONENTS

REV A

How to Remove a Drive Motor

- 1 Block the wheels at the non-steer end of the machine.
- 2 Remove the cotter pin from the wheel castle nut of the motor to be removed at the steer end of the machine.

Note: Always replace the cotter pin with a new one when removing the castle nut.

- 3 Loosen the wheel castle nut. Do not remove it.
- 4 Center a lifting jack under the drive chassis at the steer end of the machine.
- 5 Raise the machine approximately 2 inches / 5 cm. Place blocks under the chassis for support.

WARNING Crushing hazard. The chassis could fall if not properly supported.

- 6 Remove the wheel castle nut. Remove the wheel.

- 7 Tag, disconnect and plug the hydraulic hoses on the drive motor. Cap the fittings on the drive motor.

WARNING Bodily injury hazard. Spraying hydraulic oil can penetrate and burn skin. Loosen hydraulic connections very slowly to allow the oil pressure to dissipate gradually. Do not allow oil to squirt or spray.

NOTICE Component damage hazard. Hoses can be damaged if they are kinked or pinched.

- 8 Remove the drive motor mounting fasteners. Remove the motor.

Torque specifications

Drive motor mounting fasteners, dry	75 ft-lbs 101.7 Nm
Drive motor mounting fasteners, lubricated	56 ft-lbs 76.3 Nm

REV A

STEER AXLE COMPONENTS

8-2 Steer Cylinder

How to Remove the Steer Cylinder

Note: When removing a hose assembly or fitting, the O-ring on the fitting and/or hose end must be replaced and then torqued to specification during installation. Refer to Section Two, *Hydraulic Hose and Fitting Torque Specifications*.

- 1 Block the wheels at the non-steer end of the machine.
- 2 Remove the steer cylinder hose guard bracket from the machine.
- 3 Remove the pin retaining fasteners from the steer cylinder barrel-end pivot pin. Remove the pin.

Note: Observe and note the quantity and location of the spacers when removing the pivot pin.

- 4 Remove the pin retaining fasteners from the steer cylinder rod-end pivot pin. Remove the pin.

Note: Observe and note the quantity and location of the spacers when removing the pivot pin.

- 5 Remove the steer cylinder from the machine.
- 6 Tag, disconnect and plug the hydraulic hoses from the steer cylinder. Cap the fittings.

AWARNING Bodily injury hazard. Spraying hydraulic oil can penetrate and burn skin. Loosen hydraulic connections very slowly to allow the oil pressure to dissipate gradually. Do not allow oil to squirt or spray.

NOTICE Component damage hazard. Hoses can be damaged if they are kinked or pinched.

8-3 Steer Bellcrank

How to Remove the Steer Bellcrank

- 1 Remove the steer cylinder. See 8-2, *How to Remove the Steer Cylinder*.
- 2 Center a lifting jack under the drive chassis at the steer end of the machine.
- 3 Raise the machine approximately 14 inches / 36 cm. Place blocks under the chassis for support.

AWARNING Crushing hazard. The chassis could fall if not properly supported.

- 4 Turn the yokes fully to one side of the machine.
- 5 Remove the fasteners securing the bell crank to the steer yoke.

Note: Observe and note the quantity and location of the spacers between the bellcrank and the steer links.

- 6 Turn the yokes fully to the opposite side of the machine.

Note: Observe and note the quantity and location of the spacers between the bellcrank and the steer links.

- 7 Remove the fasteners securing the bell crank to the steer yoke.
- 8 Remove the bellcrank from the machine.

Note: Observe and note the quantity and location of the spacers between the bellcrank and the steer links.

Non-steer Axle Components

REV A

9-1 Drive Brake

How to Remove a Drive Brake

Note: When removing a hose assembly or fitting, the fitting and/or hose end must be torqued to specification during installation. Refer to Section 2, *Hydraulic Hose and Fitting Torque Specifications*.

- 1 Block the wheels at the steer end of the machine.
- 2 Remove the cotter pin from the wheel castle nut at the non-steer end of the machine.

Note: Always replace the cotter pin with a new one when removing the castle nut.

- 3 Loosen the wheel castle nut. Do not remove it.
- 4 Center a lifting jack under the drive chassis at the non-steer end.
- 5 Raise the machine approximately 2 inches / 5 cm. Place blocks under the chassis for support.

▲WARNING Crushing hazard. The chassis could fall if not properly supported.

- 6 Remove the wheel castle nut. Remove the wheel.

- 7 Tag, disconnect and plug the hydraulic hose from the brake. Cap the fitting on the brake.

▲WARNING Bodily injury hazard. Spraying hydraulic oil can penetrate and burn skin. Loosen hydraulic connections very slowly to allow the oil pressure to dissipate gradually. Do not allow oil to squirt or spray.

- 8 Place a lifting jack under the brake for support.
- 9 Remove the fasteners that attach the brake to the drive chassis. Remove the brake.

▲CAUTION Crushing hazard. The brake will fall if not properly supported when the mounting fasteners are removed.

Torque specifications

Brake mounting fasteners, dry	75 ft-lbs 102 Nm
Brake mounting fasteners, lubricated	56 ft-lbs 76 Nm

REV A Brake Release Hand Pump Components

10-1 Brake Release Hand Pump Components

The brake release hand pump manifold is mounted behind the hydraulic power unit.

Index No.	Description	Schematic Item	Function	Torque
1	Hand pump	J	Manual brake release	30 ft-lbs / 41 Nm
2	Needle valve, pilot operated	K	Manual brake release enable	45-50 in-lbs / 5 Nm

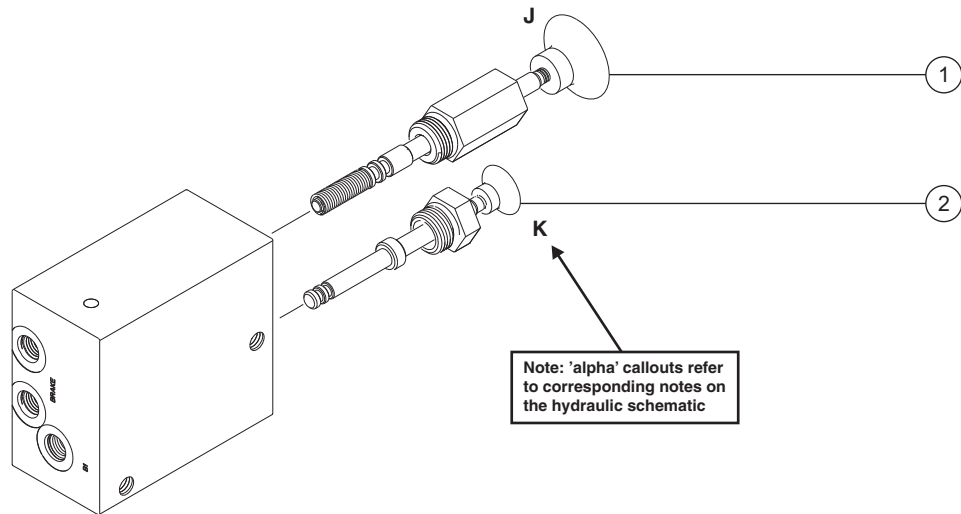

Platform Overload Components

REV B

11-1 Platform Overload System

Calibrate the Platform Overload System (if equipped)

Note: Perform this procedure with the machine on a firm, level surface.

- 1 Raise the platform approximately 2 feet / 70 cm.
- 2 Tag and disconnect the wire harness from the load sense limit switch.

Note: The load sense limit switch is located near the platform support.

- 3 Set a multi-meter to measure continuity. Connect the leads from the multi-meter to the black and red wires disconnected from the limit switch in step 2.
- 4 Determine the maximum platform capacity. Refer to the machine serial plate.
- 5 Using a suitable lifting device, place a test weight equal to that of the maximum platform capacity at the center of the platform floor. Secure the weight to the platform. Refer to the chart below.

Standard Platform (GR-12 and GR-15 models)	227 kg
(GR-20 models)	159 kg

Stockpicker Platform (GR-12, GR-15, QS-12R, QS-15R, QS-12W and QS-15W models)	227 kg
(GR-20, QS-20R and QS-20W models)	159 kg

Determine the limit switch trigger point:

- 6 Gently move the platform up and down by hand, so it bounces 1 to 2 inches / 2.5 to 5 cm.
- 7 Check the continuity between the black and red wires originating from the limit switch of the platform overload assembly.
 - ⊙ Result: **There is no continuity.** Slowly tighten the load spring adjustment nut by turning it clockwise just until the limit switch closes and shows continuity.
 - ⊙ Result: **There is continuity.** Slowly loosen the load spring adjustment nut by turning it counterclockwise just until the limit switch opens and shows no continuity.

Note: The platform will need to be continuously moved up and down while making adjustments.

Fine adjustment of the switch trigger point:

- 8 Continue moving the platform up and down and adjust the load spring adjustment nut clockwise or counterclockwise just until the limit switch is alternately opening and closing.

Note: When the limit switch is adjusted correctly, there will be continuity slightly longer than no continuity.

- 9 Remove the continuity tester from the limit switch wires. Securely install the wires onto the limit switch.

REV B

PLATFORM OVERLOAD COMPONENTS

Confirm the setting:

- 10 Turn the key switch to platform control.
- 11 Lift the test weight off the platform floor using a suitable lifting device.
- 12 Place the test weight back onto the platform floor using a suitable lifting device.
 - ⦿ Result: The diagnostic display at the ground controls will show two flat bars and a blinking light, indicating a normal condition, and the diagnostic display at the platform controls will show the battery condition. Refer to Repair procedure 1-3, *How to Determine the Battery Voltage*.
- 13 Add an additional weight to the platform not to exceed 20% of the maximum rated load. Refer to the machine serial plate.
 - ⦿ Result: The diagnostic display will show 'OL' at both the ground and platform controls. The platform overload system is operating properly.
 - ✗ Result: The diagnostic display at the ground controls will show two flat bars and a blinking light and the diagnostic display at the platform controls will show the battery condition. The platform overload system is not operating properly. Repeat this procedure beginning with step 1.
- 14 Test all machine functions from the platform controls.
 - ⦿ Result: All platform control functions should not operate.
- 15 Turn the key switch to ground control.
- 16 Test all machine functions from the ground controls.
 - ⦿ Result: All ground control functions should not operate.

Obstruction Sensing System

REV A

12-1 Obstruction Sensing Pads

The function of the Obstruction Sensing System is to detect a person or an object standing on the machine chassis. When a person or an object is detected on top of the machine chassis, the machine platform down function will not operate and an alarm will sound.

How to Replace an Obstruction Sensing Pad (QSR models only)

- 1 Raise the platform approximately 5 feet / 152 cm.
 - 2 Turn the key switch to the off position and disconnect the battery pack from the machine.
- ⚠ WARNING** Electrocuting/burn hazard. Contact with electrically charged circuits could result in death or serious injury. Remove all rings, watches and other jewelry.
- 3 At the non-steer end of the machine, unlatch the covers and open the ground controls cover.
 - 4 Working with the obstruction sensing pad to be replaced, locate the pad cables.
 - 5 Carefully pull the cables to identify the connector cable located at the ground controls, non-steer end of the machine.
 - 6 After the connector cable has been identified, tag and disconnect the cable from the obstruction sensing pad cables.
- Note: If the ground controls side or battery box cover obstruction sensing pad is replaced, carefully remove the appropriate pin from the male Deutsch connector. A new Deutsch pin will have to be installed onto the cable wire of the new ground controls side pad, or battery box cover pad.
- 7 Using a broad flat metal blade, carefully slide the metal blade under the obstruction pad and work the metal blade under the entire pad to be replaced, until the pad is separated from the chassis or the battery box cover.
 - 8 Remove the pad from the machine and carefully scrape away any excess adhesive from the chassis or battery box cover.
 - 9 Using a suitable solvent, clean the surface where the obstruction sensing pad was removed. Allow the surface to dry thoroughly.
 - 10 Install the new obstruction sensing pad.
- Note: It may be necessary to use touch-up paint in the area where the obstruction sensing pad was removed. Let the paint dry completely, before installing the new obstruction sensing pad.

REV A

OBSTRUCTION SENSING PADS

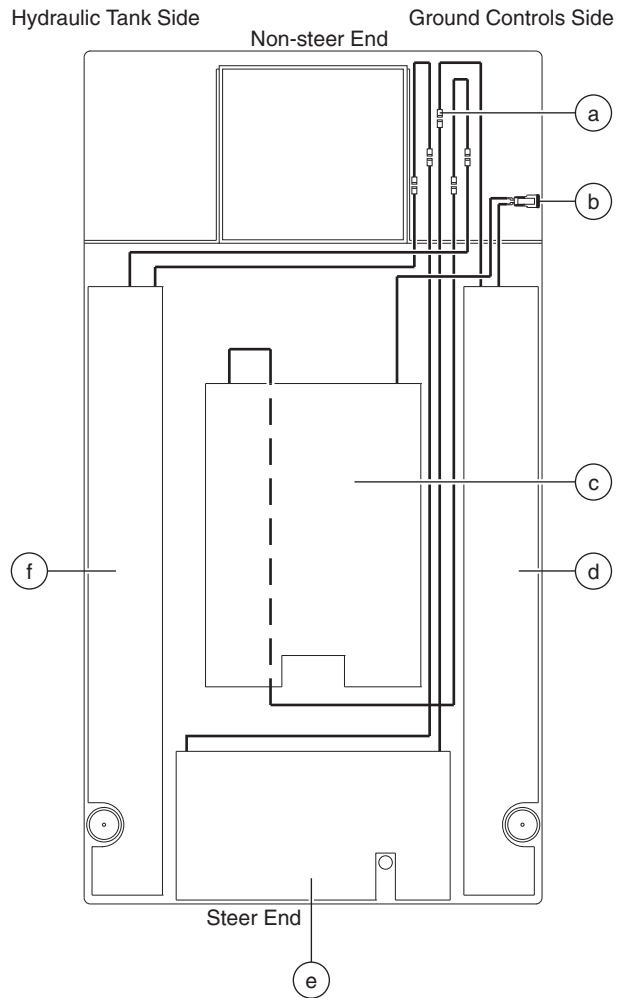

Obstruction Sensing Pads

- a cable connectors
- b Deutsch connector
- c battery box
- d obstruction sensing pad
ground controls side
- e obstruction sensing pad
steer end
- f obstruction sensing pad
hydraulic tank side

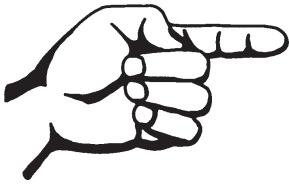

This page intentionally left blank.

Fault Codes



Observe and Obey:

- ☑ Troubleshooting and repair procedures shall be completed by a person trained and qualified on the repair of this machine.
- ☑ Immediately tag and remove from service a damaged or malfunctioning machine.
- ☑ Repair any machine damage or malfunction before operating the machine.
- ☑ Unless otherwise specified, perform each repair procedure with the machine in the following configuration:
 - Machine parked on a firm, level surface
 - Platform in the stowed position
 - Key switch in the off position with the key removed
 - The red Emergency Stop button in the off position at both ground and platform controls
 - Wheels chocked
 - All external AC power supply disconnected from the machine

Before Troubleshooting:

- ☑ Read, understand and obey the safety rules and operating instructions in the appropriate operator's manual on your machine.
- ☑ Be sure that all necessary tools and test equipment are available and ready for use.
- ☑ Be aware of the following hazards and follow generally accepted safe workshop practices.

⚠ DANGER Crushing hazard. When testing or replacing any hydraulic component, always support the structure and secure it from movement.

⚠ WARNING Electrocution/burn hazard. Contact with electrically charged circuits could result in death or serious injury. Remove all rings, watches and other jewelry.

⚠ WARNING Bodily injury hazard. Spraying hydraulic oil can penetrate and burn skin. Loosen hydraulic connections very slowly to allow the oil pressure to dissipate gradually. Do not allow oil to squirt or spray.

About This Section

When a malfunction is discovered, the fault code chart in this section will help a service professional pinpoint the cause of the problem. To use this section, basic hand tools and certain pieces of test equipment are required—voltmeter, ohmmeter, pressure gauges.

General Repair Process

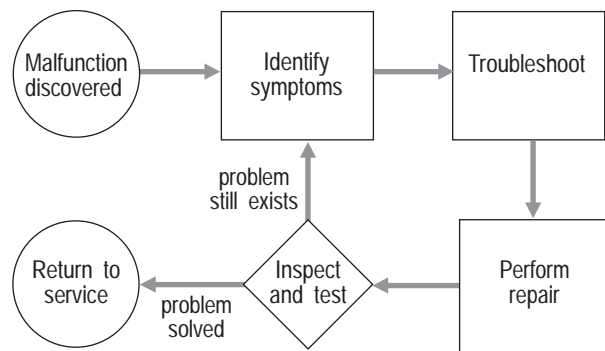

LED Diagnostic Readout

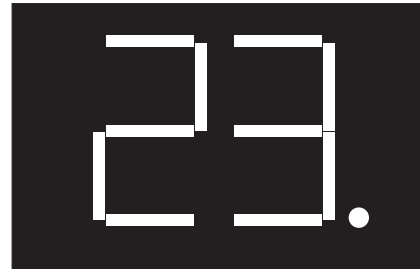

The diagnostic readout displays numerical codes that provide information about the machine operating status and about malfunctions. The dot to the right of the numbers remain on when a fault code is displayed.

The codes listed in the Fault Code Chart describe malfunctions and can aid in troubleshooting the machine by pinpointing the area or component affected.

Fault Code Chart

REV C

Fault Code	Problem	Possible Causes	Solution
01	Internal ECM error.	EPROM not programmed.	Replace ECM.
02	ECM/Platform communication error.	Malfunctioning control cable OR malfunctioning platform controls.	Troubleshoot control cable OR troubleshoot platform controls.
03	Undefined platform DIP switch settings.	DIP switch settings incorrect.	Correct DIP switch settings.
12	Chassis up/down toggle closed at start up.	Malfunctioning up/down switch.	Troubleshoot up/down switch.
18	Pothole guard failure.	Malfunctioning pothole switch OR obstruction in pothole guard linkage.	Troubleshoot pothole switch OR remove obstruction.
19	Limit switch failure.	Malfunctioning limit switch OR wire disconnected from limit switch.	Troubleshoot limit switch OR inspect wire connection.
42	Platform left turn switch fault.	Malfunctioning steer left microswitch.	Troubleshoot steer left microswitch.
43	Platform right turn switch fault.	Malfunctioning steer right microswitch.	Troubleshoot steer right microswitch.
46	Platform drive enable switch fault.	Malfunctioning drive enable switch.	Troubleshoot drive enable switch.
47	Platform joystick fault.	Joystick potentiometer not centered.	Verify potentiometer setting.
52	Forward coil fault.	Malfunctioning coil OR wire disconnected from coil.	Troubleshoot coil OR inspect wire connection.
53	Reverse coil fault.	Malfunctioning coil OR wire disconnected from coil.	Troubleshoot coil OR inspect wire connection.
54	Up coil fault. (Not used on GS-3232)	Malfunctioning coil OR wire disconnected from coil.	Troubleshoot coil OR inspect wire connection.
55	Down coil fault OR Obstruction sensing system error	Malfunctioning coil OR wire disconnected from coil. Person OR object detected on the obstruction sensing pads.	Troubleshoot coil OR inspect wire connection. Clear the obstruction sensing pads of personnel OR objects.
56	Steer right coil fault.	Malfunctioning coil OR wire disconnected from coil.	Troubleshoot coil OR inspect wire connection.
57	Steer left coil fault.	Malfunctioning coil OR wire disconnected from coil.	Troubleshoot coil OR inspect wire connection.
58	Brake coil fault.	Malfunctioning coil OR wire disconnected from coil.	Troubleshoot coil OR inspect wire connection.
59	Series/parallel coil fault.	DIP switch settings are incorrect.	Troubleshoot and correct DIP switch settings.
68	Low battery voltage.	Batteries discharged.	Charge batteries.
LL	Off level fault.	Tilt of chassis exceeds level sensor setting	Reduce chassis angle.
OL	Overload cutout fault.	Too much weight in platform	Remove weight.



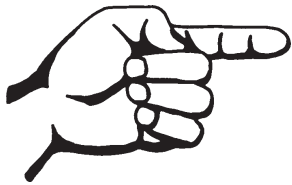

This page intentionally left blank.

Schematics



Observe and Obey:

- ☑ Troubleshooting and repair procedures shall be completed by a person trained and qualified on the repair of this machine.
- ☑ Immediately tag and remove from service a damaged or malfunctioning machine.
- ☑ Repair any machine damage or malfunction before operating the machine.

Before Troubleshooting:

- ☑ Read, understand and obey the safety rules and operating instructions in the appropriate operator's manual on your machine.
- ☑ Be sure that all necessary tools and test equipment are available and ready for use.

About This Section

There are two groups of schematics in this section. An illustration legend precedes each group of drawings.

Electrical Schematics

⚠WARNING Electrocutation/burn hazard. Contact with electrically charged circuits could result in death or serious injury. Remove all rings, watches and other jewelry.

Hydraulic Schematics

⚠WARNING Bodily injury hazard. Spraying hydraulic oil can penetrate and burn skin. Loosen hydraulic connections very slowly to allow the oil pressure to dissipate gradually. Do not allow oil to squirt or spray.

General Repair Process

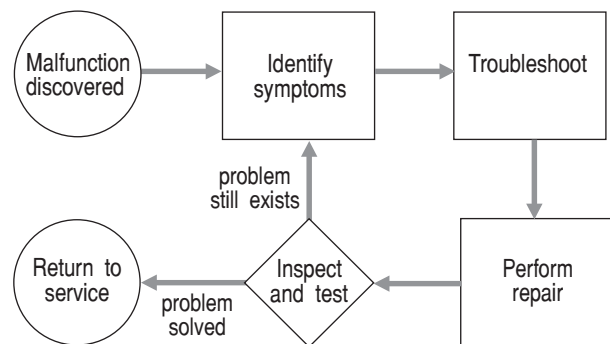

Electrical Component and Wire Color Legends

REV C

ELECTRICAL COMPONENT LEGEND	
Item	Description
B5	Battery
BN	Button
	BN5 = Horn
	BN6 = High torque
	BN8 = Drive enable
	BN9 = Lift enable
C5	Capacitor, 4700 uF
CB2	Circuit breaker, 7A
CR	Control relay
	CR5 = Horn relay (with H2 option)
	CR27A = Overload (motor controller) (option)
	CR27B = Overload (load sense) (option)
	CR27C = Overload (down coil) (option)
	CR48 = Power relay to U5 (e-stop)
	CR58 = Keypad relay (Keypad option)
	CR111A = Obstruction sensing (QS retail)
	CR111B = Obstruction sensing (QS retail)
	D7
EN4	Enclosure - AC outlet box
F6	Fuse, 275A
FB	Flashing beacons
G	Gauge
	G6 = Hour meter
	G8 = Diagnostic display
GND	Ground
H	Horn or alarm
	H1 = Horn
	H2 = Automotive-style horn (option)
	H5 = Multifunction alarm
	H10 = Obstruction sensing (QS retail)
JC1	Joystick controller
KS1	Key switch
L	LED or light
	L16 = Lift
	L17 = Drive
	L21 = High torque
LS	Limit switch
	LS6 = Platform down
	LS7 = Pothole
	LS8 = Pothole
	LS19 = Load sense (option)
M5	Hydraulic power unit
NC	Normally closed
NO	Normally open
NCHO	Normally closed held open

ELECTRICAL COMPONENT LEGEND	
Item	Description
P	Power switch
	P1 = Emergency Stop button at ground controls P2 = Emergency Stop button at platform controls
QD	Quick disconnect
	QD1 = Battery quick disconnect
	QD3 = Control cable to ground
	QD4 = Control cable to platform
R	Resistor 25 Ohm/25Watt (QS retail)
SW	Switch
	SW5 = Function enable SW6 = Steer left/right
S7	Tilt level sensor
TS66	Platform up/down toggle switch
U	Electronic component
	U3 = Platform controls printed circuit board
	U5 = Electronic control module
	U6 = Motor controller
	U9 = Battery charger
	U13 = Voltage inverter (option)
	U38 = Keypad (option)
	U47A = Obstruction sensing pad (hydraulic tank side) (QS retail)
	U47B = Obstruction sensing pad (battery tray) (QS retail)
	U47C = Obstruction sensing pad (steer end) (QS retail)
	U47D = Obstruction sensing pad (ground controls side) (QS retail)
Y	Valve coil
	Y3 = Steer right
	Y4 = Steer left
	Y5 = Drive reverse
	Y6 = Drive forward
	Y7 = Platform down
	Y8 = Platform up

WIRE COLOR LEGEND	
Color	Description
BK	Black
BK/WH	Black/White
BL	Blue
BL/BK	Blue/Black
BN	Brown
GN	Green
GN/BK	Green/Black
GN/YL	Green/Yellow
GY	Gray
LB	Light Blue
OR	Orange
OR/BK	Orange/Black
PP	Purple
RD	Red
RD/BK	Red/Black
WH	White
WH/BK	White/Black
YL	Yellow

ECM Pin-out Legend

REV B

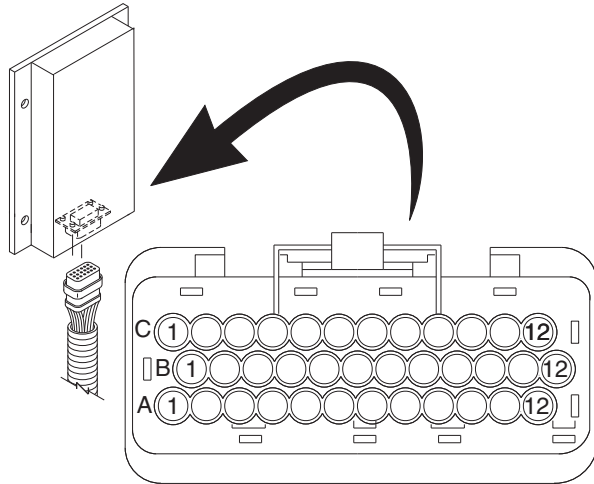

ECM PIN-OUT LEGEND	
Item	Description
A1	Flashing beacon FB1 (output)
A2	Ground from platform controls (input) (White wire at platform controls)
A3	Plug
A4	Driver Power (input)
A5	Level sensor power S7 (output)
A6	Platform up coil Y8 (output)
A7	Drive reverse coil Y5 (output)
A8	Motor controller U6, terminal 1
A9	Motor controller U6, terminal 3
A10	Overload sensor PS2 (input)
A11	Key switch to platform control (input)
A12	Platform down TS66 (input)
B1	Platform data link (high) (input) (Blue wire at platform controls)
B2	Plug
B3	ECM ground (output)
B4	Plug
B5	Plug
B6	Platform down coil Y7 (output)
B7	Steer left coil Y4 (output)
B8	Automotive-style horn H2 (option) (output)
B9	Multi-function alarm H5 (output)
B10	Pothole limit switch (input)
B11	Drive enable power/up limit switch (input)
B12	Platform up TS66 (input)
C1	Platform data link (low) (input) (Orange wire at platform controls)
C2	Power to ECM (input)
C3	Plug
C4	Plug
C5	Jumper
C6	Drive forward coil Y6 (output)
C7	Steer right coil Y3 (output)
C8	Plug
C9	Plug
C10	Jumper
C11	Level sensor signal S7 (input)
C12	Down limit switch LS66 (input)

Relay Layout

REV C

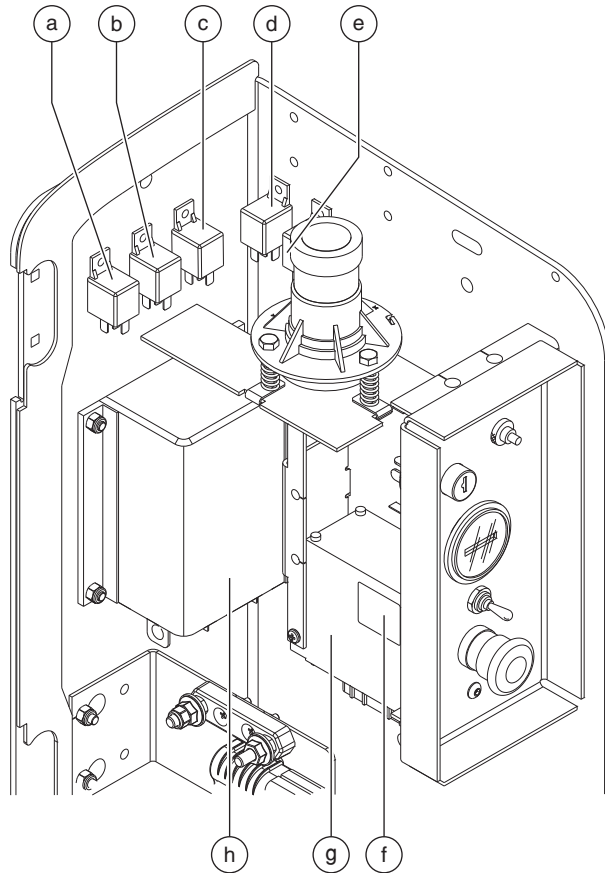

Relay Layout - GR and QSW

- a platform overload CR27A (motor cont) (option)
- b platform overload CR27B (load sense) (option)
- c platform overload CR27C (down coil) (option)
- d auto-style horn CR5 (option)
- e power relay CR48
- f ECM diagnostic display window
- g electronic control module (ECM) U5
- h motor controller U6

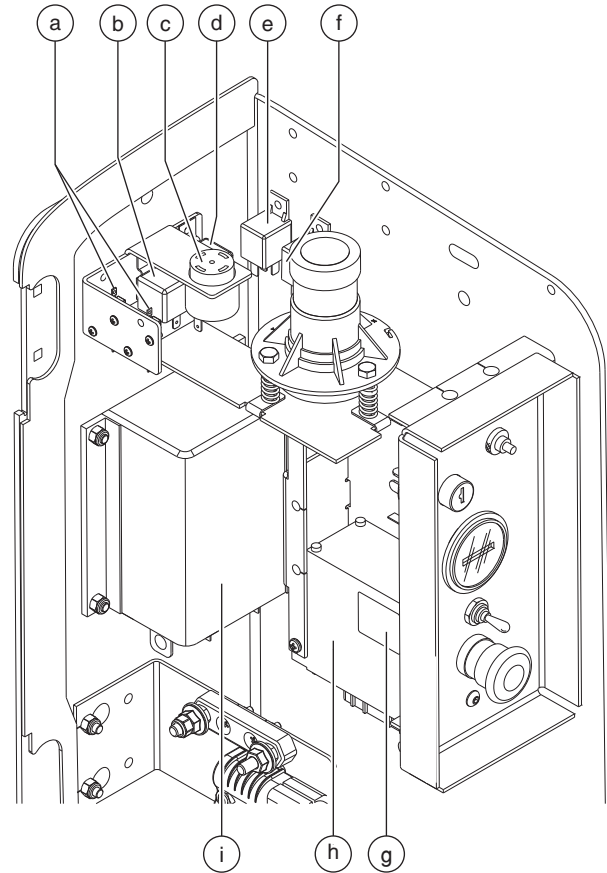

Relay Layout - QSR

- a resistor 25 ohm/25 watt
- b obstruction sensing CR111A (QS retail)
- c obstruction sensing alarm
- d obstruction sensing CR111B (QS retail)
- e auto-style horn CR5 (option)
- f power relay CR48
- g ECM diagnostic display window
- h electronic control module (ECM) U5
- i motor controller U6

REV B

Wiring Diagram

Ground and Platform Controls

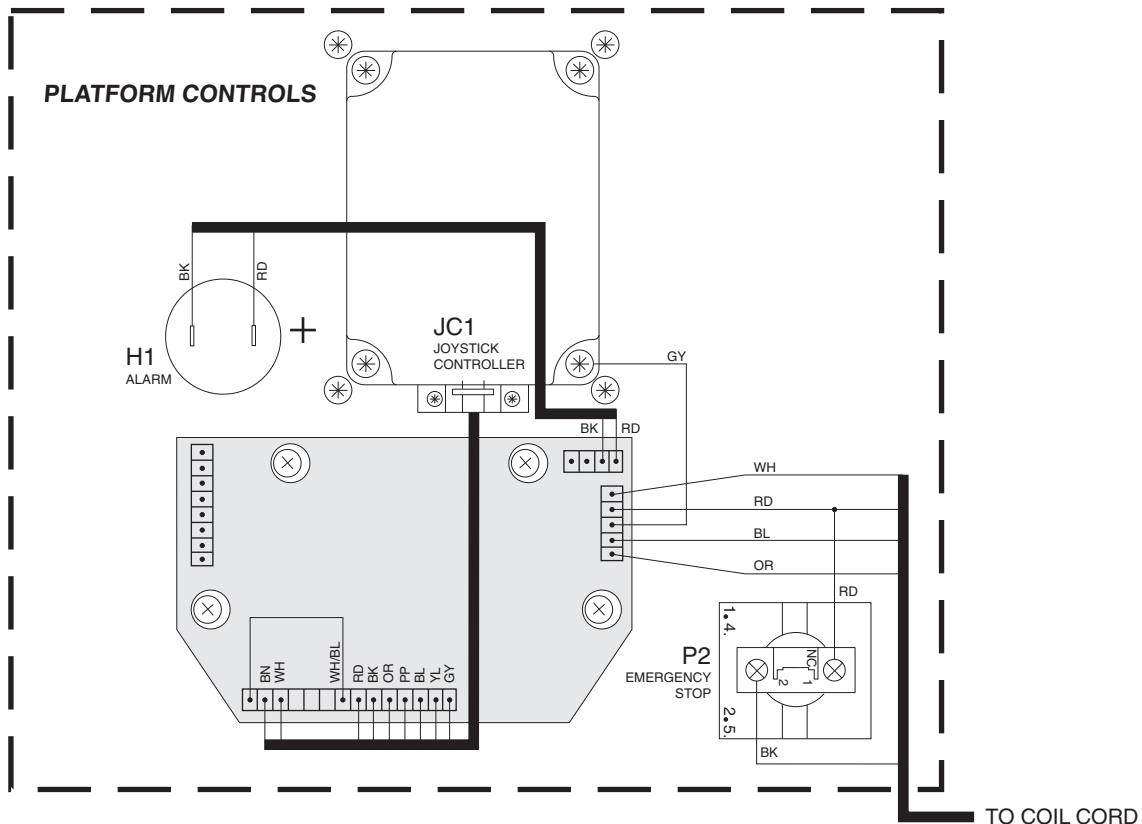
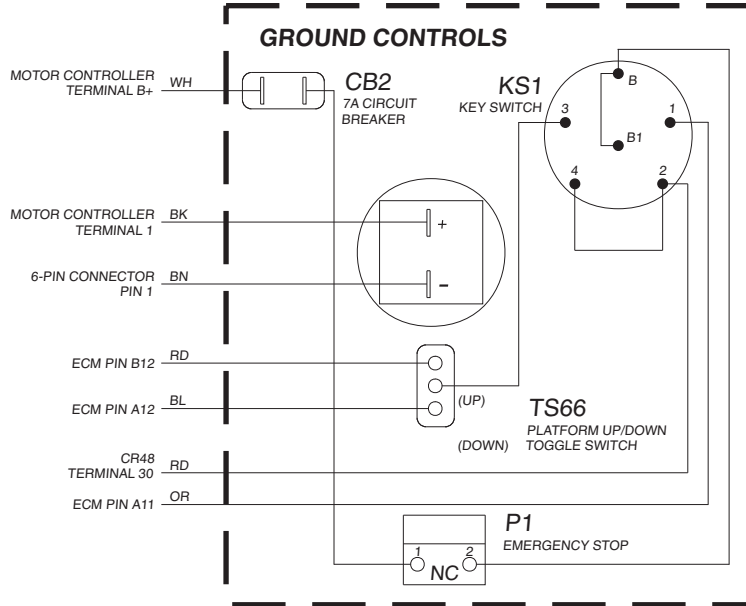

Electrical Symbols Legend

REV B

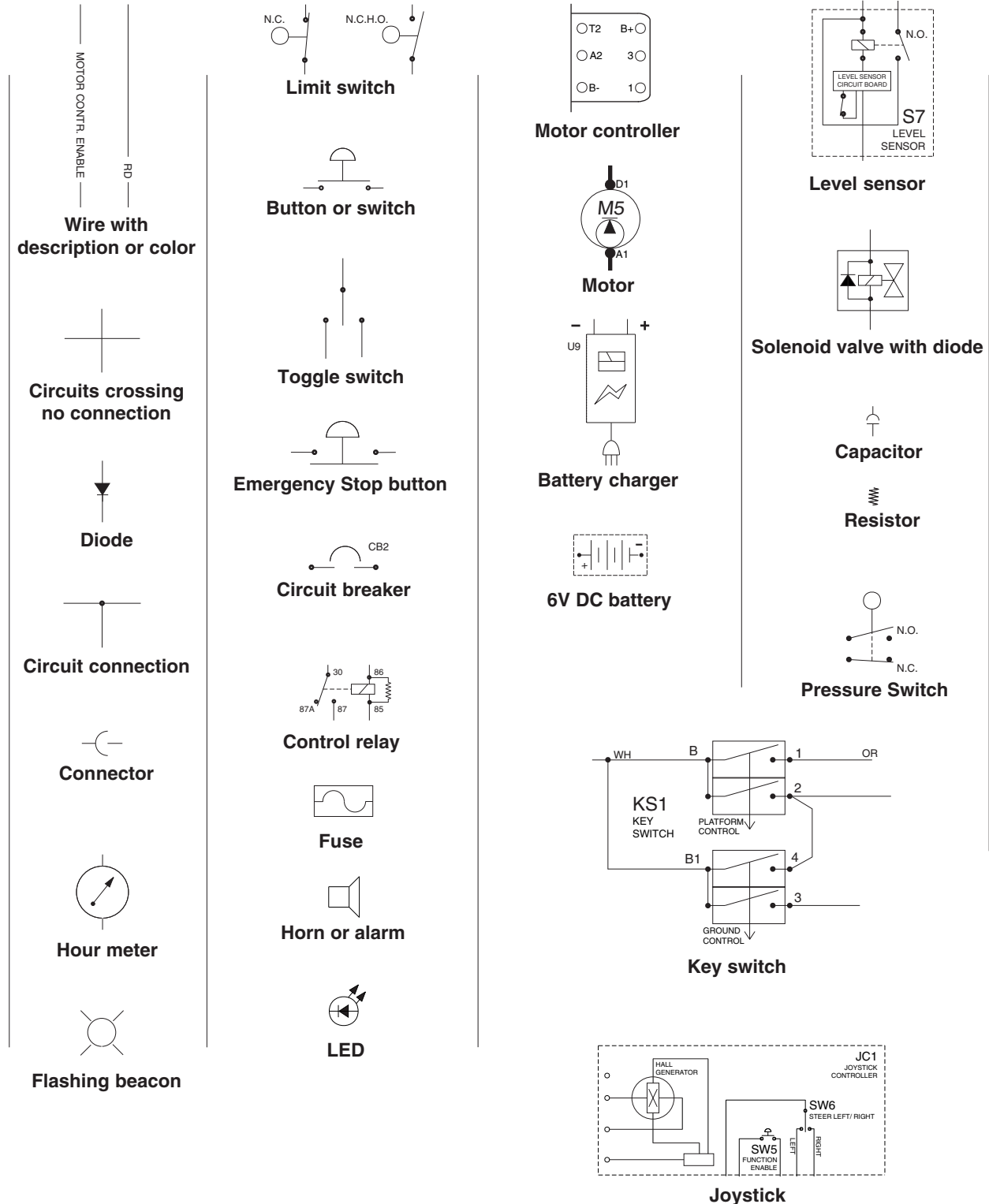

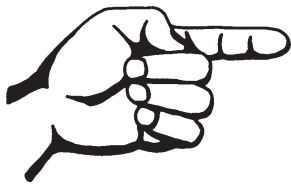

This page intentionally left blank.

Electrical Schematic - GR and QSW

ANSI and CSA Models
Part 1 of 2

REV C

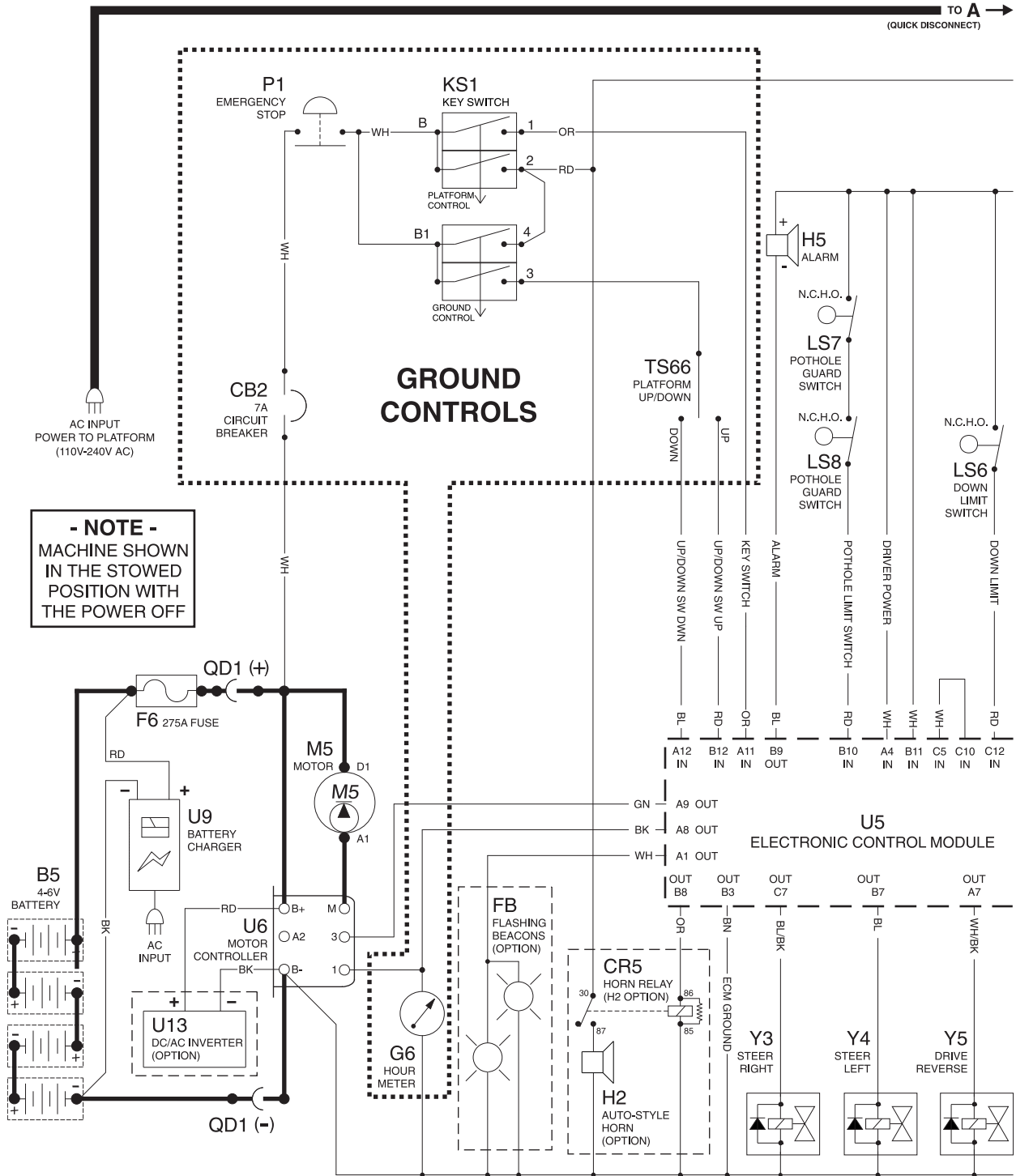

- NOTE -
MACHINE SHOWN
IN THE STOWED
POSITION WITH
THE POWER OFF

ES0126C



Electrical Schematic - GR and QSW

ANSI and CSA Models

Part 2 of 2

REV C

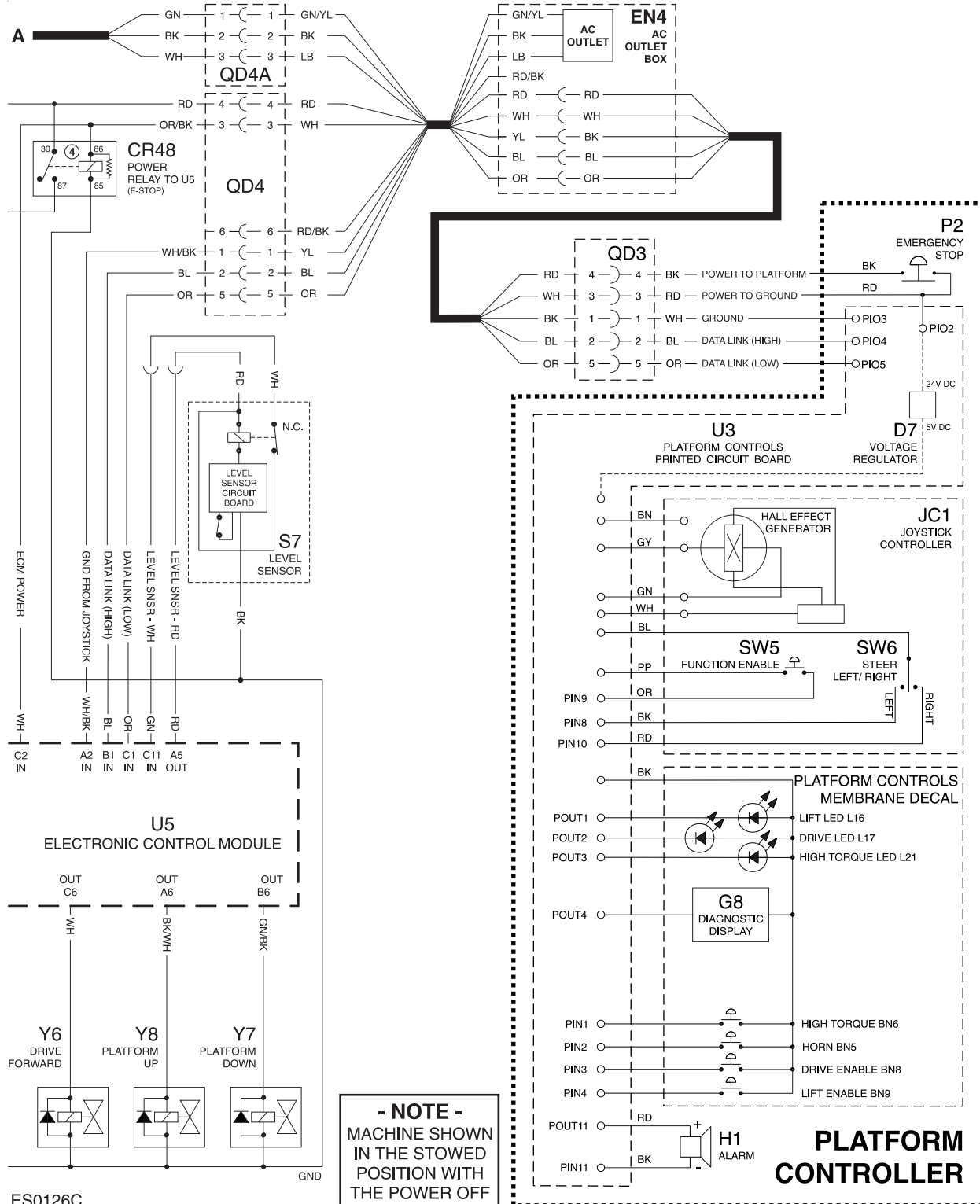

ES0126C



Electrical Schematic - GR and QSW

CE Models
Part 1 of 3

REV D

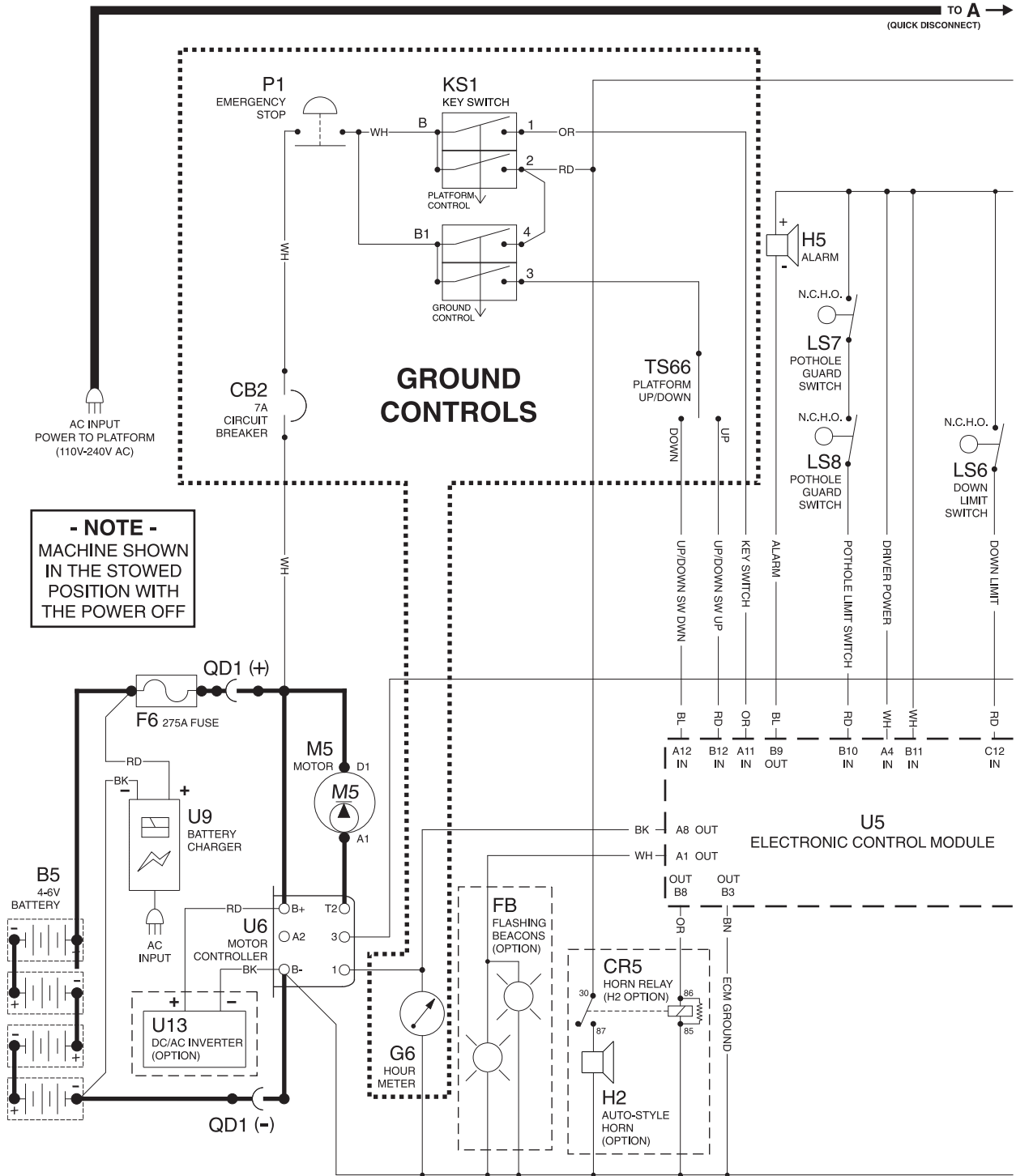

- NOTE -
MACHINE SHOWN
IN THE STOWED
POSITION WITH
THE POWER OFF

ES0127D



Electrical Schematic - GR and QSW

REV D

CE Models
Part 2 of 3

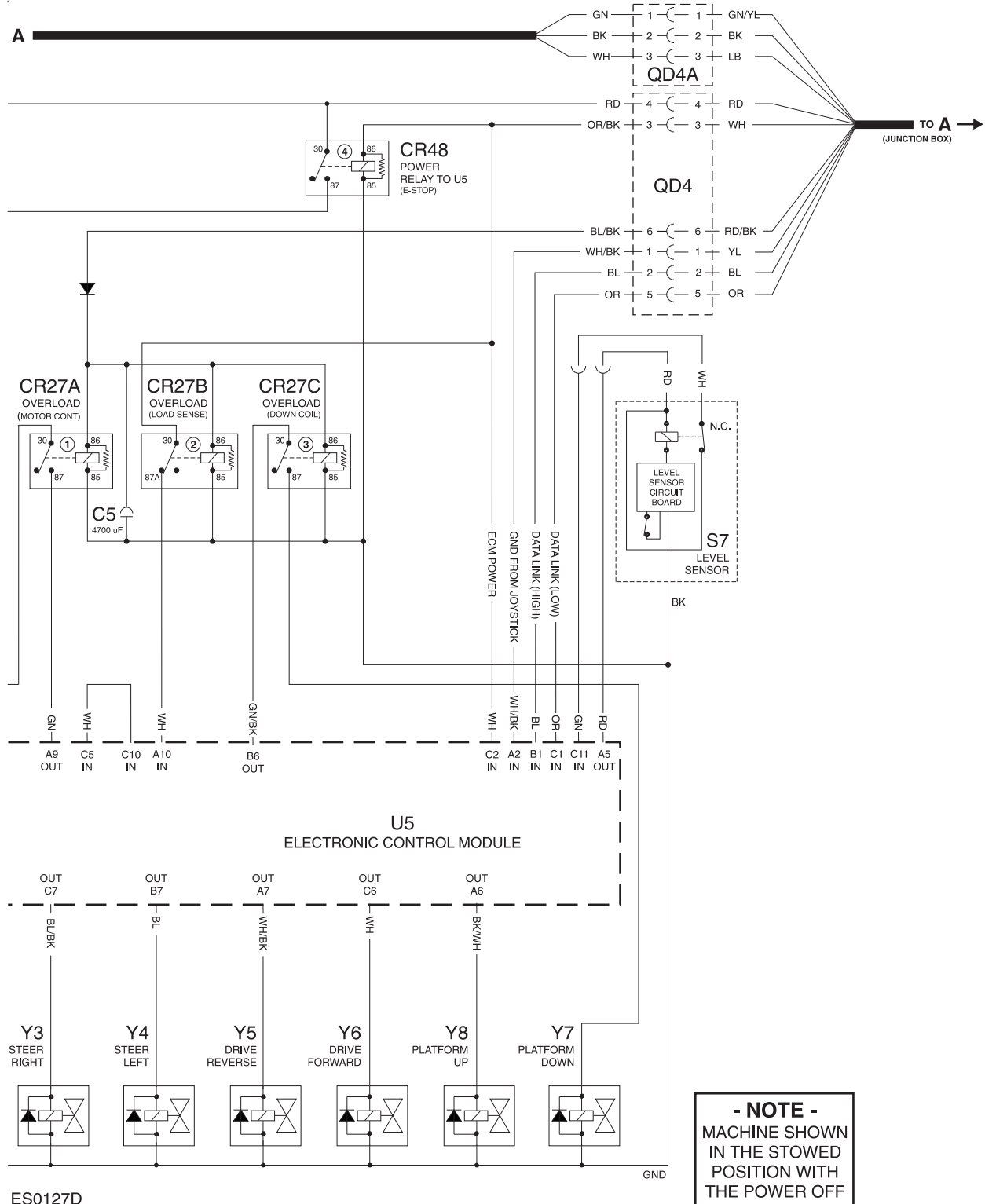

ES0127D



Electrical Schematic - GR and QSW

CE Models
Part 3 of 3

REV D

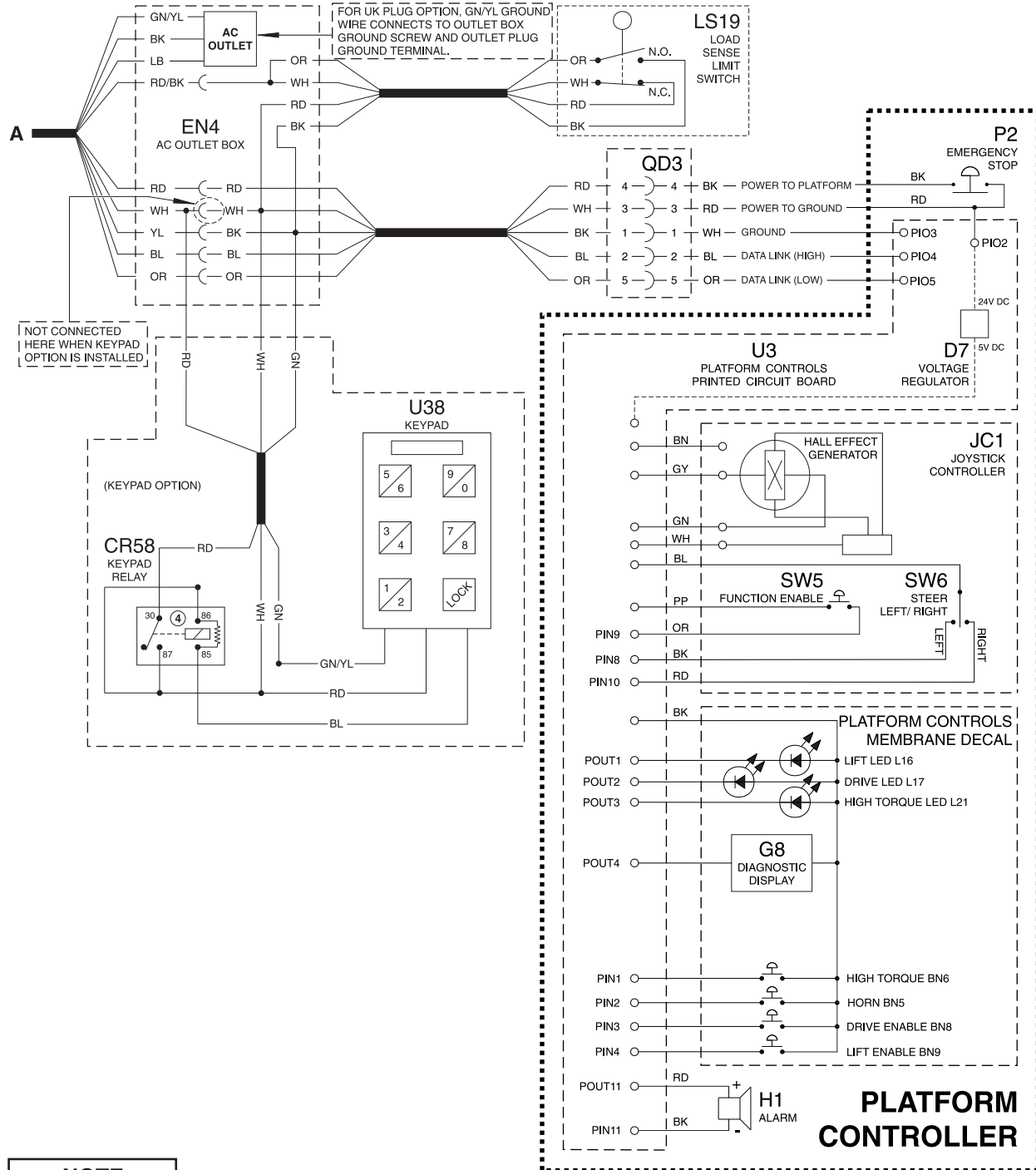

- NOTE -
MACHINE SHOWN
IN THE STOWED
POSITION WITH
THE POWER OFF

ES0127D



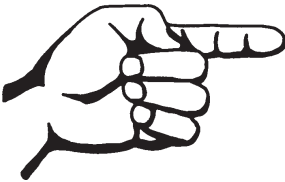

This page intentionally left blank.

Electrical Schematic - QSR

ANSI and CSA Models

REV A

Part 1 of 3

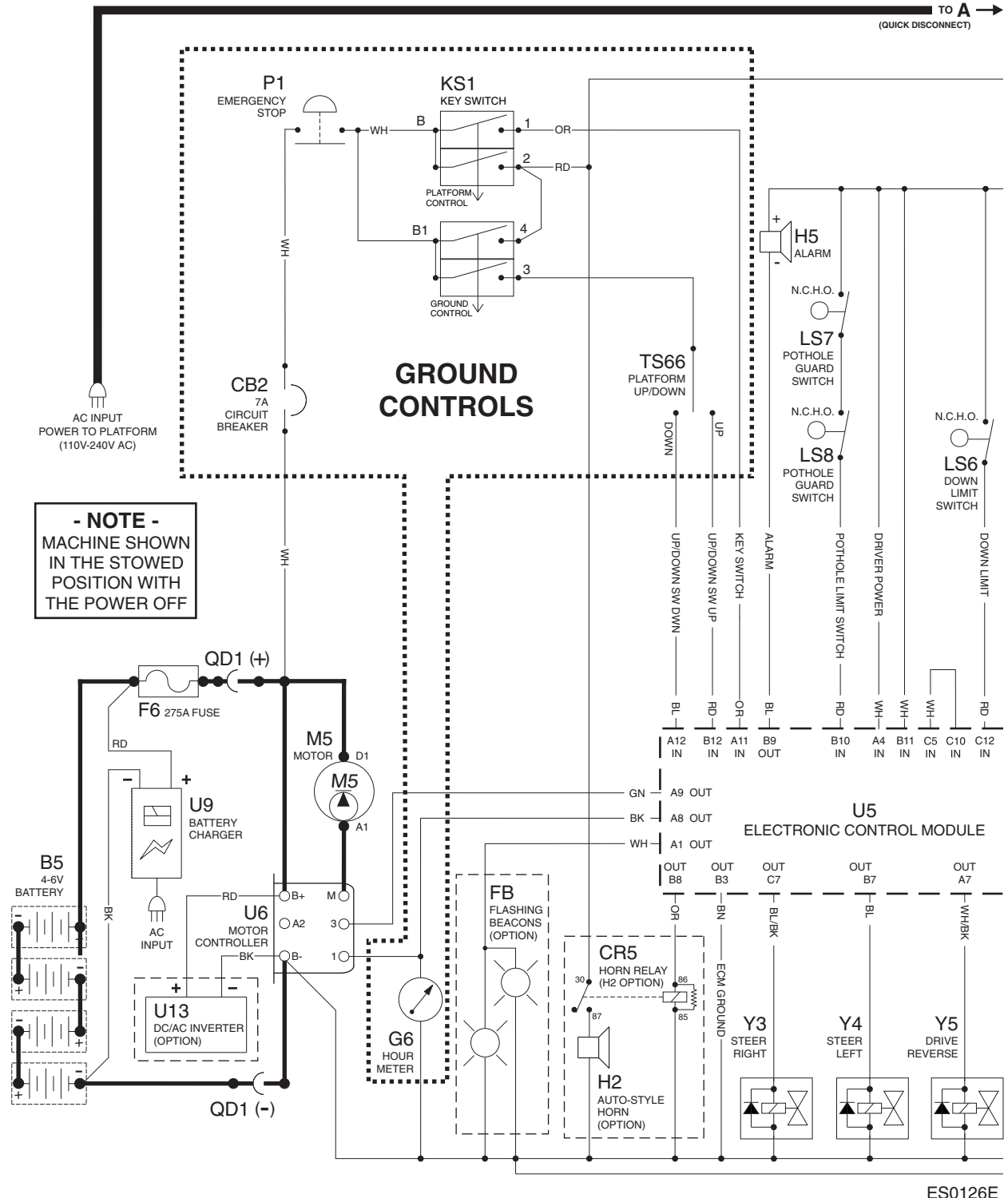

Electrical Schematic - QSR

ANSI and CSA Models

Part 2 of 3

REV A

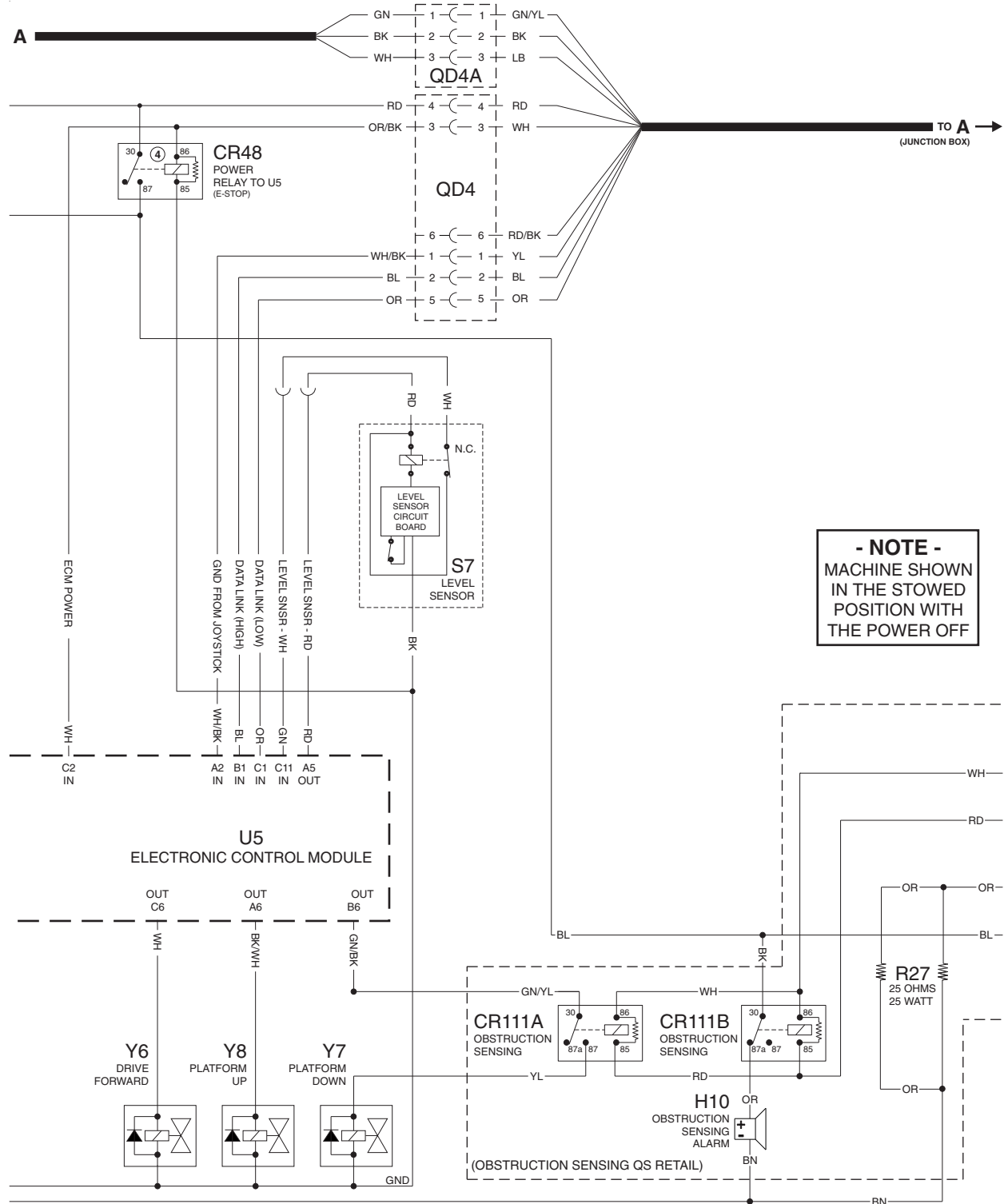

ES0126E



Electrical Schematic - QSR

ANSI and CSA Models

REV A

Part 3 of 3

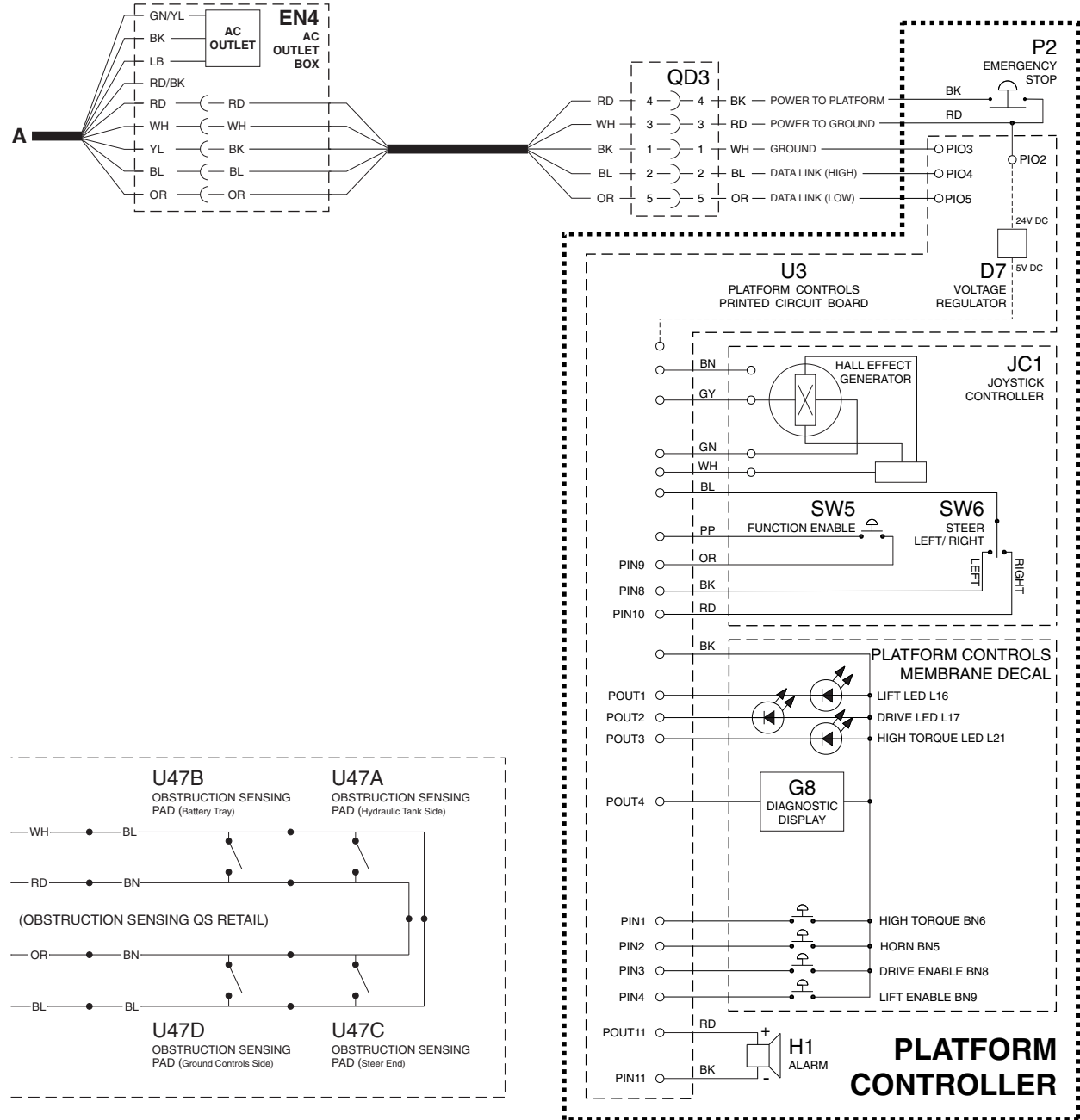

- NOTE -
MACHINE SHOWN
IN THE STOWED
POSITION WITH
THE POWER OFF

ES0126E



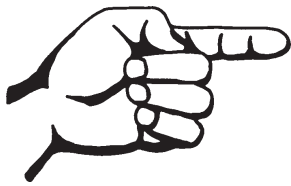

This page intentionally left blank.

Electrical Schematic - QSR

CE Models
Part 1 of 3

REV A

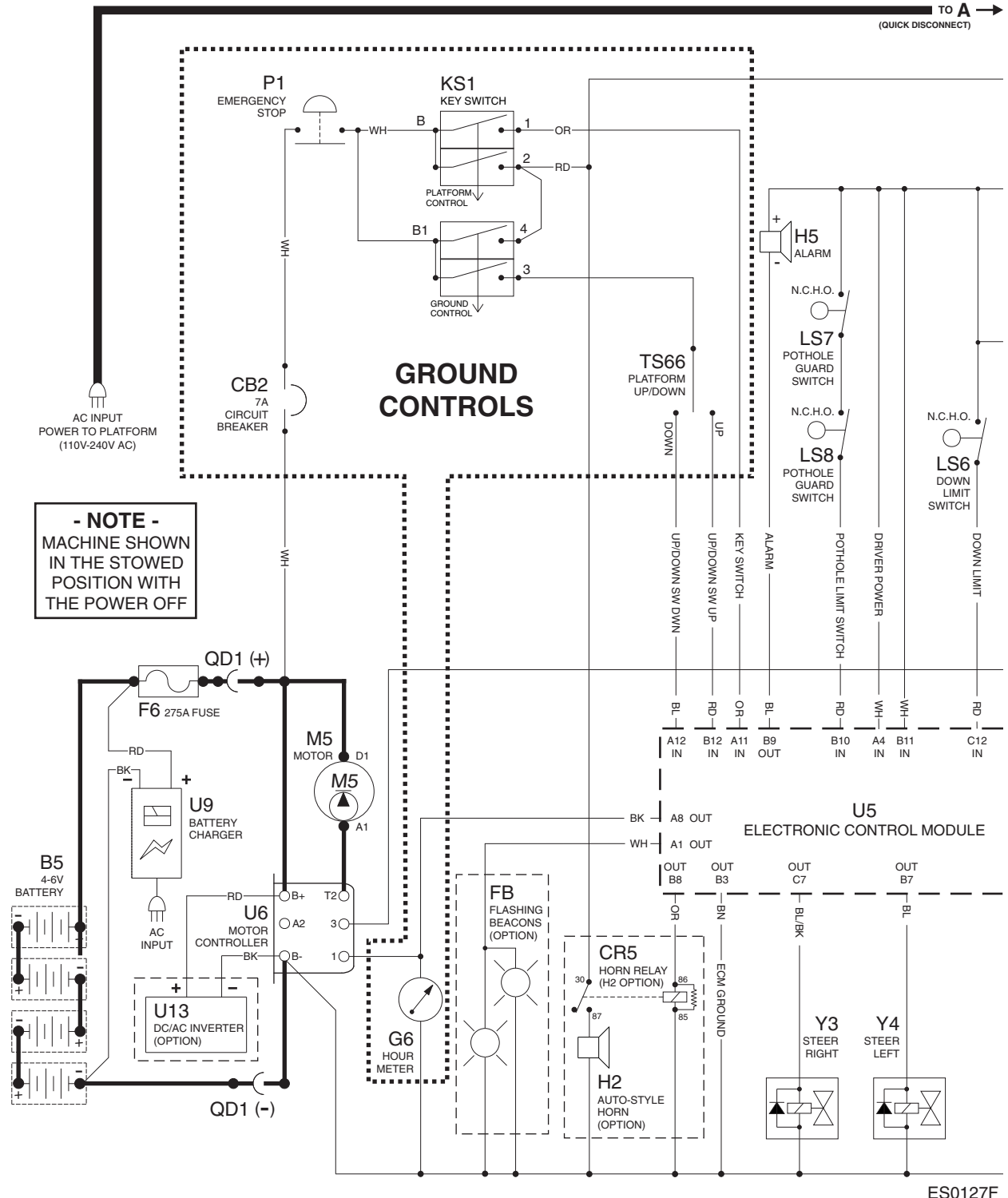

ES0127F



Electrical Schematic - QSR

CE Models
Part 3 of 3

REV A

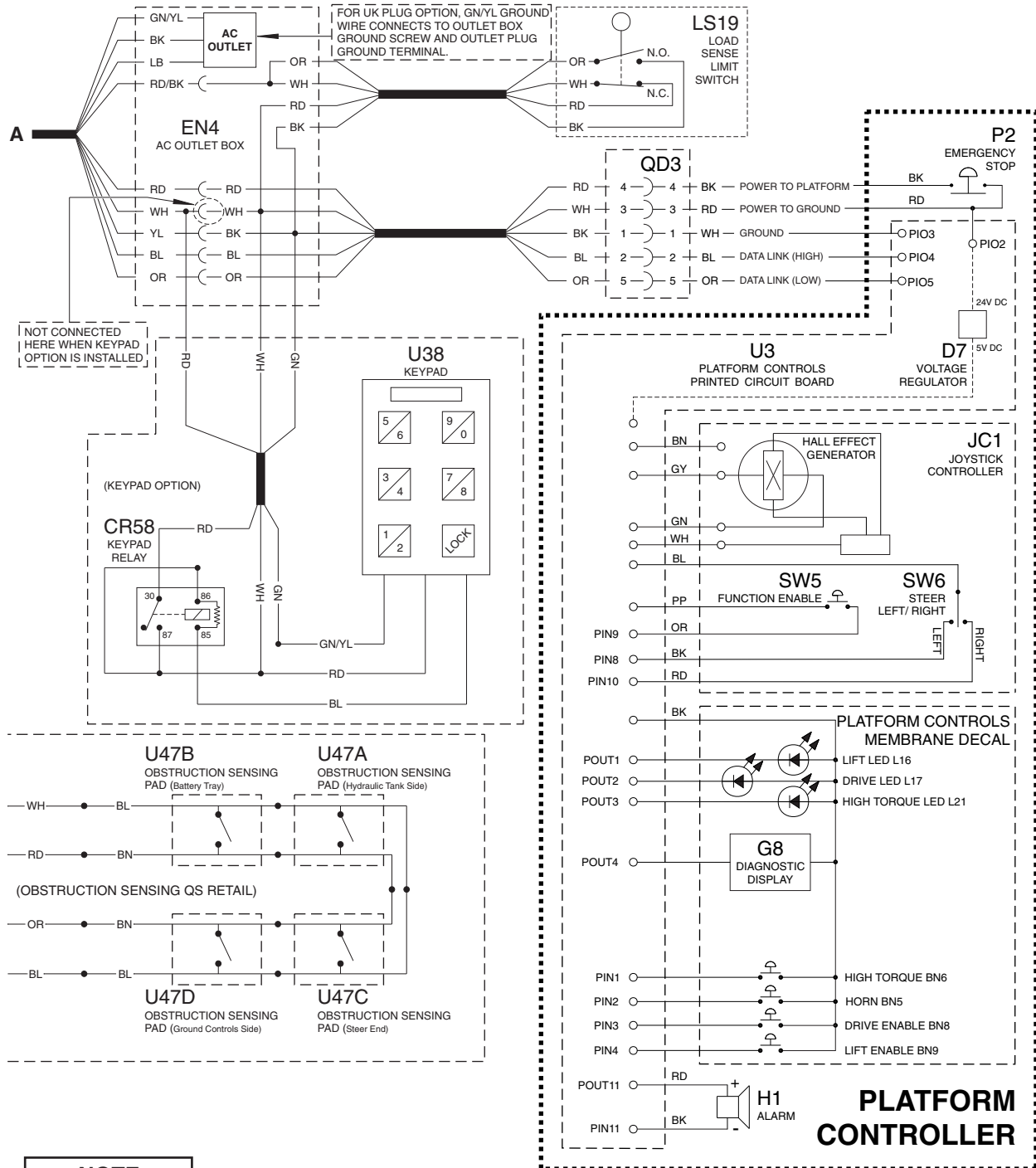

- NOTE -
MACHINE SHOWN
IN THE STOWED
POSITION WITH
THE POWER OFF

ES0127F



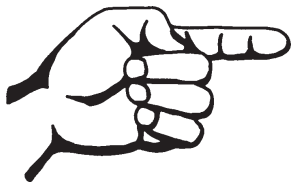

This page intentionally left blank.

Hydraulic Component Reference and Symbols Legend

REV A



Orifice



Variable speed motor



Brake



Check valve

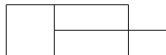

Hydraulic cylinder



Fixed displacement pump



Solenoid operated
2 position 4 way
directional valve

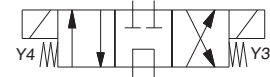

Solenoid operated
3 position 4 way
directional valve

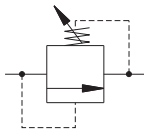

Relief valve



Bi-directional motor

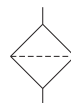

Filter

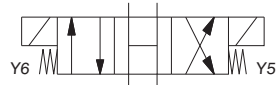

Solenoid operated
3 position 4 way
directional valve

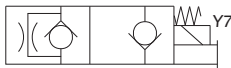

Solenoid operated
2 position 2 way
directional valve
normally closed
with manual override

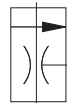

Priority flow regulator

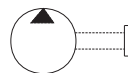

Hand pump

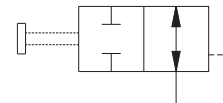

Pilot operated
needle valve

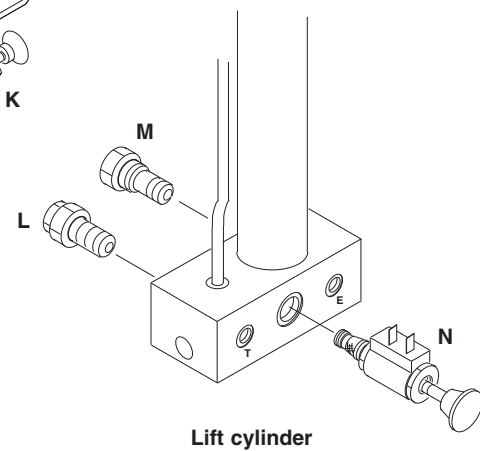
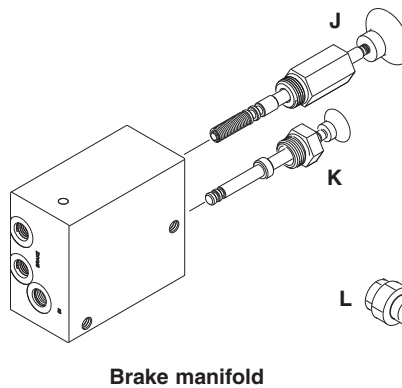
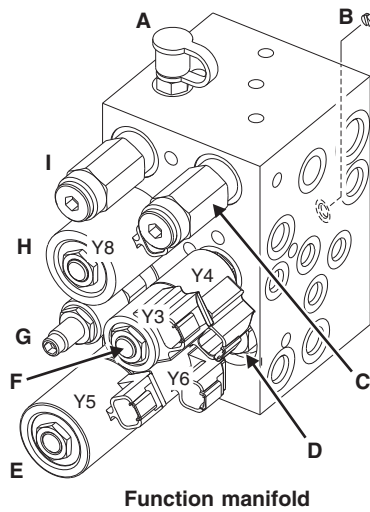

Hydraulic Schematic

REV A

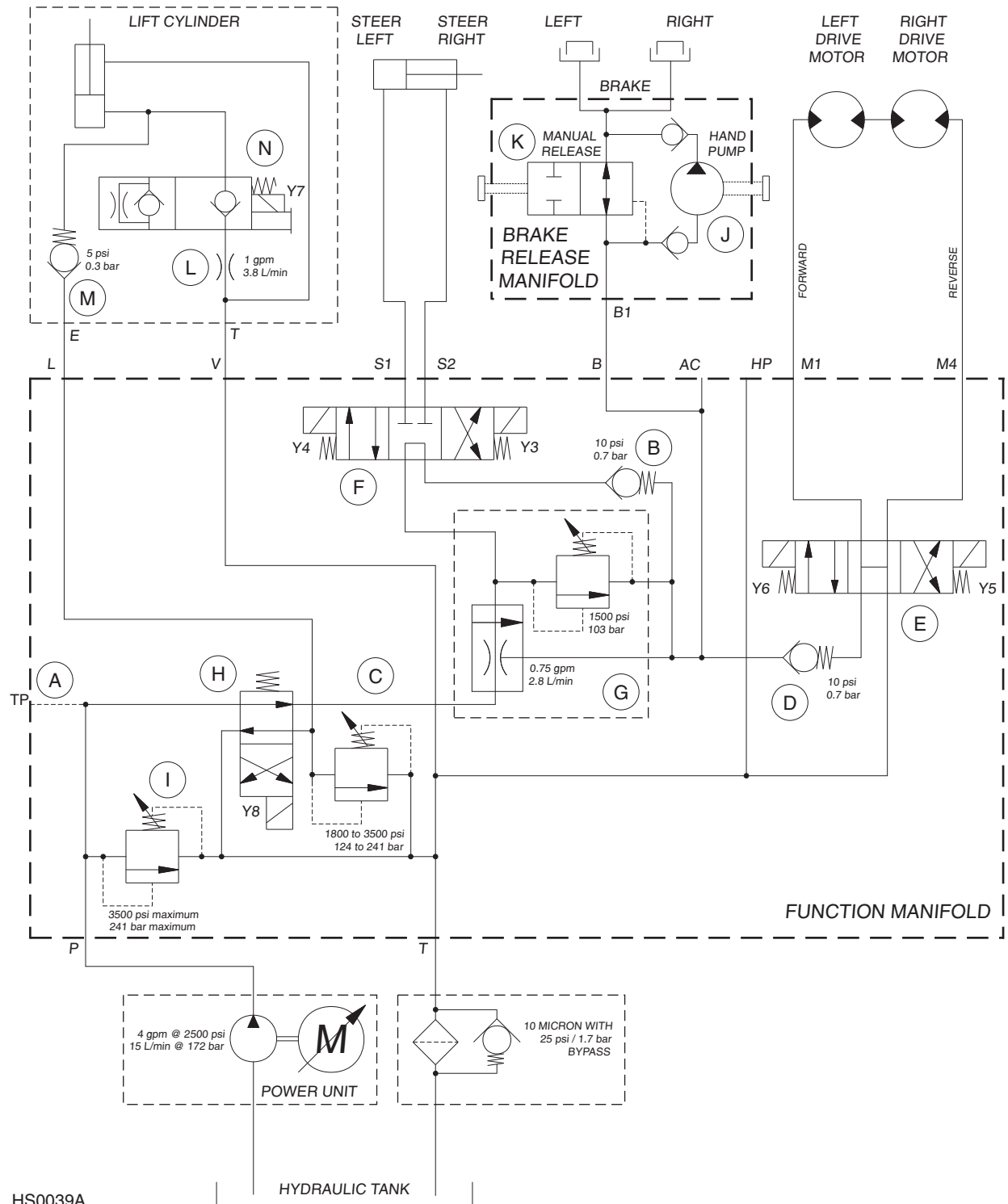

HS0039A



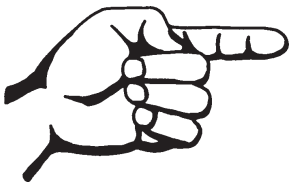

This page intentionally left blank.

Genie Scandinavia

Phone +46 31 575100
Fax +46 31 579020

Genie France

Phone +33 (0)2 37 26 09 99
Fax +33 (0)2 37 26 09 98

Genie Iberica

Phone +34 93 579 5042
Fax +34 93 579 5059

Genie Germany

Phone 0800 180 9017
Phone +49 422 149 1818
Fax +49 422 149 1820

Genie U.K.

Phone +44 (0)1476 584333
Fax +44 (0)1476 584334

Genie Mexico City

Phone +52 55 5666 5242
Fax +52 55 5666 3241

Genie North America

Phone 425.881.1800
Toll Free USA and Canada
800.536.1800
Fax 425.883.3475

Genie Australia Pty Ltd.

Phone +61 7 3375 1660
Fax +61 7 3375 1002

Genie China

Phone +86 21 53852570
Fax +86 21 53852569

Genie Malaysia

Phone +65 98 480 775
Fax +65 67 533 544

Genie Japan

Phone +81 3 3453 6082
Fax +81 3 3453 6083

Genie Korea

Phone +82 25 587 267
Fax +82 25 583 910

Genie Brasil

Phone +55 11 41 665 755
Fax +55 11 41 665 754

Genie Holland

Phone +31 183 581 102
Fax +31 183 581 566

Distributed By:

Service Manual
GR • QSR • OSW

(from serial number GR05-5001)
(from serial number QS09-101)

Part No.
84700

Rev C1

Genie
A TEREX COMPANY